



Analysis of voltage multiplier circuit simulation for rain energy harvesting using circular piezoelectric



Nik Ahmad Kamil Zainal Abidin, Norkharziana Mohd Nayan*, Muhammad Mokhzaini Azizan, Azuwa Ali

Power Electronics Control and Optimization Research Group (PECO), Centre of Excellence for Renewable Energy (CERE), School of Electrical System Engineering, Universiti Malaysia Perlis, Pauh Putra Campus, 02600 Arau, Perlis, Malaysia

ARTICLE INFO

Article history:

Received 3 March 2017
Received in revised form 8 July 2017
Accepted 9 August 2017

Keywords:

Vibration
Piezoelectric
Voltage doubler
CWCVD
KFCVD
Rain energy

ABSTRACT

Piezoelectric energy harvester extracts energy based on the magnitude of vibration source and the resonant frequency. In order to get the maximum voltage output, the piezoelectric must receive higher vibration to obtain the frequency near at its resonant frequency. However, it is difficult to obtain the high and stable of vibration from the surrounding to impact on the piezoelectric. Therefore, in order to fix this problem, the voltage multiplier circuit is designed to improve the magnitude of the output gained from the piezoelectric. In order to analyze the potential output produce from rain energy, this paper present three types of circuit for investigation which are voltage doubler, Cockcroft Walton Cascade Voltage Doubler (CWCVD) and Karthaus Fischer Cascade Voltage Doubler (KFCVD). The output voltage and current were investigated to obtain the optimum output based on the result of the simulation. The circuit then can be applied for rain energy harvesting.

© 2017 Elsevier Ltd. All rights reserved.

1. Introduction

Energy harvesting techniques is a technology to generate electrical power from capturing very small amounts of energy from one or more of the surrounding energy resources [1,2]. The research on power harvesting technology regarding became increasingly over the last decade [3–6]. The energy harvesting produces from milliwatt or microwatt of power that can be used to energize the low load devices [6,7].

The energy resources that have been focusing on this paper is vibration energy. The vibration energy can be converted into electrical energy using piezoelectric. The piezoelectric has the ability to generate an AC (alternating current) by converting mechanical energy (vibration) to electrical energy [8–11]. However, the amount of energy produced by vibration is low and not stable. Therefore, the converter circuit is necessary to optimize the amount of output from piezoelectrics such as rectifier [12,13], integrated circuit [14], voltage doubler and voltage multiplier [15].

In this paper, the converter that been focused is voltage doubler and voltage multiplier circuit. The advantages from both of this circuit are it can convert from AC to DC source, double up the output magnitude and stabilize it. The voltage multiplier is divided into two circuits which are CWCVD and KFCVD. Next, these three circuits are further investigated and compare its performance. Lastly, optimum simulation output will be implemented into the rain energy harvester device.

* Corresponding author.

E-mail address: norkharziana@unimap.edu.my (N.M. Nayan).

2. Basic operation of rain energy harvesting

This paper is focusing on the energy harvesting using vibration energy from rainfall. The flow of this paper is described in Fig. 1 which shows the block diagram of the system. When the raindrop hits the piezoelectric tiles, it will produce a vibration in an AC source form captured by the piezoelectric. The piezoelectric tile which is made from a set of circular piezoelectric is used to detect the vibration. The circular piezoelectric is used in this project as it gives a more visible surface for rain drop to hits on it when arranged in an array. The probability of rain drop on the surface is high as compared to strip piezoelectric. The resonant frequency of the circular piezoelectric being used (KSPG-10) is in the boundary of the frequency of rain drop. The resonant frequency for this piezoelectric is 1200 kHz and the maximum input voltage is 30 V peak to peak. As stated in [16,17] the frequency of rain is the range of minimum less than 500 Hz to maximum 30 kHz. The output of the vibration detected by piezoelectric is in an AC source form. The converter will convert this AC source into DC source and DC source will be feed into the battery charging circuit to stabilize the output at 5 V and increase the current before charging the lithium ion battery. The final stage is basically depending on the user either to power up low devices or directly used the power using the USB port.

3. Types and design of converter circuits

This paper will focus on the three types of voltage multiplier circuits which are voltage doubler, CWCVD [18] and KFCVD [19,20]. The basic operation of this circuits is to convert AC source to DC source and increase the amplitude of the input power after being converted. All the three circuits are simulated using Proteus software to analyze their performance. Variations of connection are done to compare the output thus validating the suitable voltage multiplier circuit for rain energy harvesting. This variation of connection includes one piezoelectric connection and sets of two series three parallel (2S3P) piezoelectric connection as shown in Fig. 2. One piezoelectric connection is done to find output power produced by one piezoelectric which will be the reference value. Then by modifying the circuit configuration into a 2S3P connection is done in order to optimize the output power.

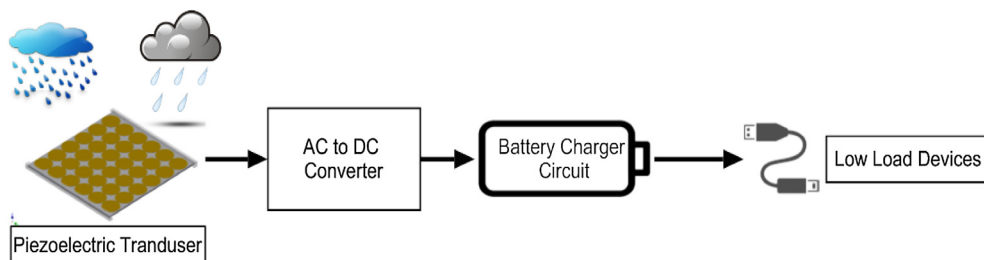

Fig. 1. Block diagram.

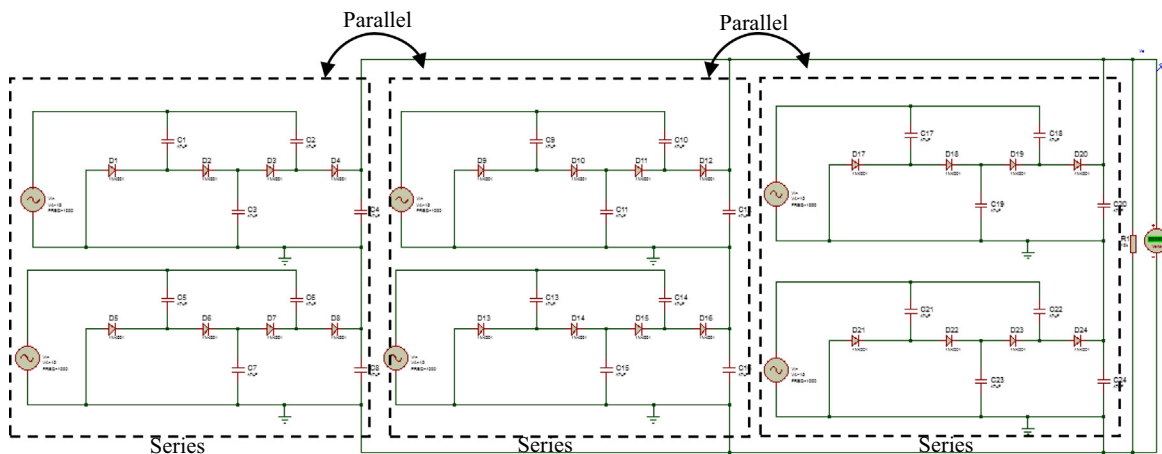

Fig. 2. KFCVD using 2S3P piezoelectric connection.

Download English Version:

<https://daneshyari.com/en/article/4976599>

Download Persian Version:

<https://daneshyari.com/article/4976599>

[Daneshyari.com](https://daneshyari.com)