



ELSEVIER

Contents lists available at ScienceDirect

ISA Transactions

journal homepage: [www.elsevier.com/locate/isatrans](http://www.elsevier.com/locate/isatrans)

# Implementation of fuzzy-sliding mode based control of a grid connected photovoltaic system

Abdelkrim Menadi<sup>a,\*</sup>, Sabrina Abdeddaim<sup>b</sup>, Ahmed Ghamri<sup>b</sup>, Achour Betka<sup>b</sup>

<sup>a</sup> Laboratoire LMSE, Electrical Engineering Department, University of Biskra, Algeria

<sup>b</sup> Laboratoire LGEB, Electrical Engineering Department, University of Biskra, Algeria

## ARTICLE INFO

### Article history:

Received 7 January 2015

Received in revised form

26 May 2015

Accepted 11 June 2015

Available online 1 August 2015

This paper was recommended for publication by Dr. Jeff Pieper

### Keywords:

Photovoltaic

Grid connected

MPPT

Sliding mode control

Fuzzy logic

Unity power factor

## ABSTRACT

The present work describes an optimal operation of a small scale photovoltaic system connected to a micro-grid, based on both sliding mode and fuzzy logic control. Real time implementation is done through a dSPACE 1104 single board, controlling a boost chopper on the PV array side and a voltage source inverter (VSI) on the grid side. The sliding mode controller tracks permanently the maximum power of the PV array regardless of atmospheric condition variations, while The fuzzy logic controller (FLC) regulates the DC-link voltage, and ensures via current control of the VSI a quasi-total transit of the extracted PV power to the grid under a unity power factor operation. Simulation results, carried out via Matlab–Simulink package were approved through experiment, showing the effectiveness of the proposed control techniques.

© 2015 Published by Elsevier Ltd. on behalf of ISA.

## 1. Introduction

As conventional energy sources are vanishing fast with a consequent rise in cost, considerable attention is being paid to other alternative sources. Nowadays, solar energy, which is free and abundant in most parts of the world, has proven to be an economical source of energy in many applications. Nowadays, grid connected PV systems have acquired a mature technology, and is receiving more attention in recent years as decentralized sources, to share the power demand in case of grid disturbances, improving therefore the stability of the interconnected networks. In this topic, various studies have been carried out on sizing [1,2], matching [3], and optimizing [4]. Different optimization strategies were proposed to improve the overall system efficiency, by extracting and then injecting the maximum PV power into the grid. The first task deals with tracking the maximum power point (MPP) of the PV array, where many algorithms are used; whereas, the second task consists in injecting this power with minimum losses. As exposed in [5,6], the conventional Perturb & Observe (PO) method does not provide a good accuracy and response time, since oscillation occurs around the optimal point in steady state

[7]. To overcome this drawback, several intelligent and complex control methods, such as fuzzy logic [8,9] genetic algorithms [10,11], neural network [12], neuro-fuzzy MPPT strategies [13], were developed in recent years to improve accuracy and response time.

Compared to the classical algorithms, artificial techniques proved a notable superiority, since the maximum power point is always tracked very fast regardless any sudden changes of solar insolation, and without oscillation in steady state [14]. As an interface with the AC side, two or multi-level VSI with various pulse width modulation techniques, are currently in use. They are controlled either in current or voltage mode to allow the PV power flow of the PV power to the utility under a controlled power factor operation.

In this scope, the present paper describes how an operation of a small scale PV system connected to a microgrid can be achieved. The main tasks assigned to the proposed control strategies are

1. A permanent tracking of the maximum power point of the PV array, by a proper tuning of the boost chopper duty cycle, using sliding mode based MPPT control.
2. A total flow of the extracted PV power to the utility, via current control of the VSI, under a unity power factor operation.

In order to investigate the system performances, and prior to numerical simulation, each part of the system is modeled, taking into account the following assumptions: the synchronization of the PV system with the grid is not considered in this study, power converters

\* Correspondence to: Laboratoire LGEB, Electrical Engineering Department, University of Biskra, Algeria. Tel.: +213 665150341.

E-mail addresses: [a.menadi@univ-biskra.dz](mailto:a.menadi@univ-biskra.dz) (A. Menadi), [s\\_abdeddaim@yahoo.fr](mailto:s_abdeddaim@yahoo.fr) (S. Abdeddaim), [ghamri65@gmail.com](mailto:ghamri65@gmail.com) (A. Ghamri), [betkaachour@gmail.com](mailto:betkaachour@gmail.com) (A. Betka).

**Nomenclature**

$V_{PV}$  photovoltaic array voltage (V)  
 $I_{PV}$  photovoltaic array current (A)  
 $I_{sc}$  photovoltaic short circuit (A)  
 $I_o$  inverse saturation current (A)  
 $V_{oc}$  PV open circuit voltage (V)  
 $V_{th}$  thermal voltage (V)  
 $R_s$  array series resistance ( $\Omega$ )  
 $\alpha$  chopper duty cycle  
 $\sigma$  sliding surface  
 $\Delta T$  temperature variation

$V_{DC}, V_{DCref}$  actual and reference DC link voltage (V)  
 $E, E_r$  actual and reference insolation ( $W/m^2$ )  
 $I_a, I_b, I_c$  grid currents (A)  
 $e_a, e_b, e_c$  grid voltages (V)  
 $V_a, V_b, V_c$  inverter output voltages (V)  
 $\theta$  grid estimated angle (rad)  
 FLC fuzzy logic controller  
 $I, I_r$  actual and reference current (A)  
 $V, V_r$  actual and reference voltage (V)  
 $\beta, \gamma$  current and voltage change coefficient depending on the temperature

are supposed lossless. Thus, the paper is organized as follows: Section 2 shows the modeling of different system components, while in Section 3, the proposed control strategies are presented. To test the effectiveness of these techniques, Section 4 illustrates both the practical and simulation results. Section 5 concludes this work.

**2. System description and modeling**

The synoptic schematic of the studied system is shown in Fig. 1. The first stage of the conversion chain is composed of a PV array and a boost DC–DC converter, which rises the relatively low optimum solar voltage into a suitable DC link value. The second stage is composed of a three phase voltage source inverter connected to the grid via an inductive filter and a step up transformer.

**2.1. PV array modeling**

Photovoltaic arrays are neither voltage nor current sources, but can be approximated as current generators with dependent voltage sources, where the  $I$ - $V$  characteristic can be expressed by an implicit Eq. [15]:

$$I_{PV} = I_{sc} - I_o \left[ \exp\left(\frac{V_{PV} + R_s I_{PV}}{V_{th}}\right) - 1 \right] \tag{1}$$

$I$ - $V$  curve is crucially influenced by solar insolation and temperature variations. The adaption of Eq. (1) to different levels of these inputs can be handled by the following equations:

$$\Delta I = \beta \left(\frac{E}{E_r}\right) \Delta T + \left(\frac{E}{E_r} - 1\right) I_{sc} \tag{2}$$

$$\Delta V = \gamma \Delta T - R_s \Delta I \tag{3}$$

$$V = V_r + \Delta V \tag{4}$$

$$I = I_r + \Delta I \tag{5}$$

**2.2. DC–DC converter model**

To test the control techniques on continuous dynamic systems, the state space average models of power converters are generally used, neutralizing so the system's discontinuity caused by the switching phenomena. Referring to Fig. 2, the continuous dynamic model of the boost DC–DC converter is obtained through the combination of the switching modes, as follows:

For  $S=0$ , the following expressions are deduced for storage elements  $L_1$  and  $C$ :

$$L_1 \frac{di_{L1}}{dt} = V_{PV} - V_{DC} \tag{6}$$

$$C \frac{dV_{DC}}{dt} = i_{L1} - \frac{V_{DC}}{R_L} \tag{7}$$

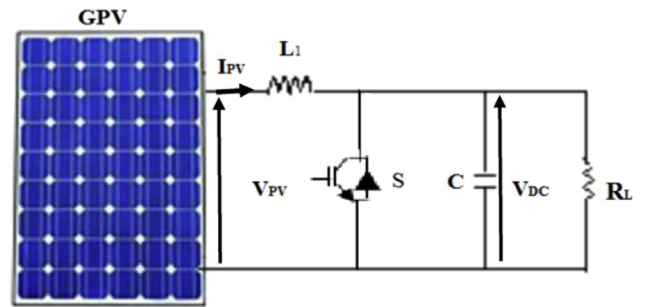

Fig. 2. DC–DC boost converter schematic.

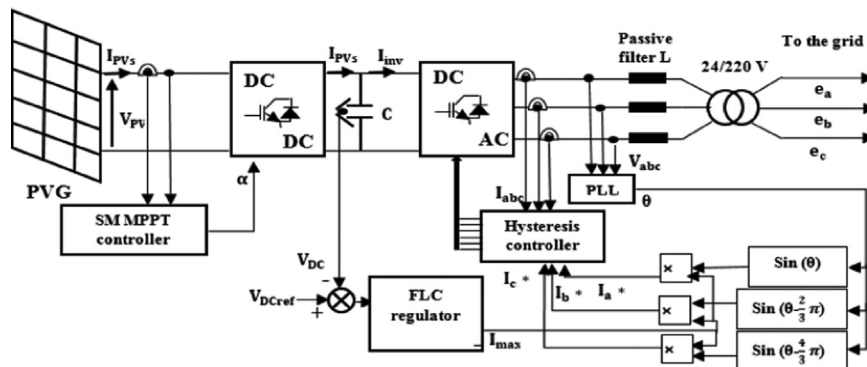

Fig. 1. Synoptic of the grid connected PV system.

Download English Version:

<https://daneshyari.com/en/article/5004572>

Download Persian Version:

<https://daneshyari.com/article/5004572>

[Daneshyari.com](https://daneshyari.com)