



Optimal allocation and maintenance of multi-state elements in series–parallel systems with common bus performance sharing [☆]



Hui Xiao ^{a,*}, Rui Peng ^b

^a School of Statistics, Southwestern University of Finance and Economics, Chengdu, Sichuan, China

^b Dongling School of Economics and Management, University of Science and Technology Beijing, Beijing, China

ARTICLE INFO

Article history:

Received 31 August 2013

Received in revised form 14 February 2014

Accepted 11 March 2014

Available online 21 March 2014

Keywords:

Reliability

Multi-state system

Performance sharing

Maintenance

Universal generating function

Genetic algorithm

ABSTRACT

This article considers the optimal allocation and maintenance of multi-state elements in series–parallel systems with common bus performance sharing. The surplus performance from a sub-system can be transmitted to any other sub-system which is experiencing performance deficiency. The amount that can be transmitted is subjected to a random transmission capacity. In order to increase the system availability, maintenance actions can be performed during the system lifetime and the system elements can be optimally allocated into the sub-systems. In this paper, we consider the element allocation and maintenance simultaneously in order to minimize the total maintenance cost subject to the pre-specified system availability requirement. An algorithm based on universal generating function is suggested to evaluate the system availability and the genetic algorithm is explored to solve the optimization problem. Numerical experiments are presented to illustrate the applications.

© 2014 Elsevier Ltd. All rights reserved.

1. Introduction

In traditional binary reliability modelling and analysis, both systems and components are considered as having two states, i.e., perfect functioning state and complete failure state. However, many industrial and engineering systems can have partial failure states besides the perfect functioning and complete failure states. For example, the power generator has several operational states, in which the capacity is different, e.g. 100 MV (full capacity), 70 MV (partial failure), 50 MV (partial failure) and 0 MV (complete failure) (Billiton & Allan, 1996). Systems with variable performance levels are usually referred to as multi-state systems (MSS), see Lisnianski and Levitin (2003) and Peng, Mo, Xie, and Levitin (2013). Comparing with the traditional reliability which is defined as the probability that the system is functioning over a specified period of time, MSS reliability is defined as the probability that system is able to meet the demand of the system over a specified period of time. The demand is the required level of performance, and it can be a random variable.

The system structure can be very complex for many industrial and engineering systems. To evaluate the system reliability, we

can consider the various multi-state elements (MEs) that make up the system. As defined in Lisnianski and Levitin (2003), if the MEs are working together to satisfy the demand, the system is defined as a parallel system and the system performance is the sum of the performance of individual ME. The reliability of the system is the probability that sum of the performance meets the total required demand. On the other hand, if each ME satisfies its own demand individually, the system is defined as a series system. The reliability of the system is the product of the probability that each ME can meet its own demand.

Series system assumes that the performance surplus from individual ME cannot be shared by other MEs that do not meet their own demands. However, the surplus performance can be transmitted to other MEs in many real situations such as power, communication, data process and production systems. Performance sharing is firstly studied by Lisnianski and Ding (2009). Only two multi-state elements are considered in the paper and the transmission is restricted in one direction. Levitin (2011) extended the idea of performance sharing to the problem where there is arbitrary number of MEs and the transmission of performance can be in any direction. The system is named as common bus performance sharing model. However, Levitin (2011) considers only a simple series system with performance sharing among MEs. In addition, the state distribution of system elements is fixed. In practice, systems may have more complex structure and the system elements are usually with increasing failure rate (Ding, Lisnianski, Frenkel, &

^{*} This manuscript was processed by Area Editor Min Xie.

^{*} Corresponding author. Address: School of Statistics, Southwestern University of Finance and Economics, 555 Liutai Avenue East Section, Wenjiang, Chengdu, Sichuan 611130, China. Tel.: +86 18628201916.

E-mail address: msxh@swufe.edu.cn (H. Xiao).

Nomenclature

E	set of all multi-state elements	A_i	availability of element e_i
E_j	set of multi-state elements located at sub-system j	$A(\bullet)$	availability of the system for a given the maintenance strategy and element allocation
e_i	multi-state element i	A^*	pre-specified system availability requirement
N	number of sub-systems connected in series	\mathbf{V}	the vector representing the allocation of each element
M	total number of multi-state elements	\mathbf{T}	the vector representing the replacement interval of each element
G_i	random performance of element e_i	$h(i)$	total number of states of element e_i
W_j	random demand of sub-system j	p_{ib}	the probability that element e_i is in state b
C	random transmission capacity of the common bus performance sharing system	g_{ib}	the performance of element e_i when it is in state b
S_j	random performance surplus of sub-system j	$u_i(\bullet)$	performance UGF of element e_i
D_j	random performance deficiency of sub-system j	$U_j(\bullet)$	performance UGF of sub-system j
Z	random amount of performance transmission	$W_j(\bullet)$	demand UGF of sub-system j
\hat{D}	system deficiency after redistribution	$\theta(j)$	total number of states of the demand for sub-system j
\hat{S}	excessive performance after redistribution	q_{jr}	the probability that the demand of sub-system j is in state r
$\lambda_i(t)$	expected number of failures for element e_i in the time horizon of $[0, t]$	w_{jr}	the demand value of sub-system j in state r
T_i	preventive replacement interval for element e_i	$\eta(\bullet)$	transmission capacity UGF of the common bus performance sharing system
$Q(i)$	set of possible preventive replacement interval alternatives	B	the total number of states of common bus performance sharing system
$\tau_j(i)$	the j th alternative of preventive replacement interval for element e_i	α_β	the probability that the common bus performance sharing system is in state β
$\kappa(i)$	total number of preventive replacement interval alternatives for element e_i	ζ_β	transmission capacity when the common bus performance sharing system is in state β
C_P	total preventive replacement maintenance cost	$\iota(i)$	the sub-system at which element e_i is located
C_M	total minimal repair cost		
C_{Total}	total maintenance cost		

Khvatskin, 2009; Levitin, 2004; Levitin & Lisnianski, 1999). For such systems, the system availability can be greatly influenced by the system element allocation and the maintenance actions taken (Chambari, Rahmati, Najafi, & Karimi, 2012; Faghih-Roohi, Xie, Ng, & Yam, 2014; Levitin, 2003; Peng, Xie, Ng, & Levitin, 2012; Wang & Li, 2014). The redundancy allocation of multi-state series-parallel systems is an important and popular research topic which has been studied by many researchers (Levitin & Lisnianski, 1999; Nourelfath, Chatelet, & Nahas, 2012; Yalaoui, Chu, & Chatelet, 2005; Zhou, Zhang, Lin, & Ma, 2013).

In this paper, we consider a multi-state series-parallel system with common bus performance sharing as shown in Fig. 1. Each sub-system consists of several MEs connected in parallel, i.e., the performance of each sub-system is the sum of the performance of individual ME within the sub-system. The surplus performance from individual sub-system can be transmitted to other sub-systems that do not meet the demand (deficient sub-systems) given that the total transmitted amount does not exceed a random transmission capacity. The transmission capacity is determined by the common bus performance sharing system. We consider a more

general scenario where the performance sharing system is a multi-state system since it may be used by multiple systems. Therefore, its transmission capacity for each system is random variable instead of a constant. The failure rate of each ME is assumed to increase with time. In order to increase the system availability, an effective way is to perform preventive replacement on the system elements to reduce their failure rates (Ambani, Meerkov, & Zhang, 2010; Levitin & Lisnianski, 1999; Liu, Li, Huang, Zuo, & Sun, 2010). As preventive replacement can be very expensive, minimal repair which simply recovers the ME to functioning state without changing its failure rate is usually adopted when the system elements fail between two successive preventive replacements (Dwyer, 2012; Soro, Nourelfath, & Ait-Kadi, 2010). The system availability is higher if the system elements are replaced more frequently, which also increases the maintenance cost. Another factor which influences the system availability is the element allocation among the sub-systems. In this paper, the joint optimal element allocation and maintenance strategy is studied in order to minimize the total maintenance cost while satisfying a pre-specified system availability requirement.

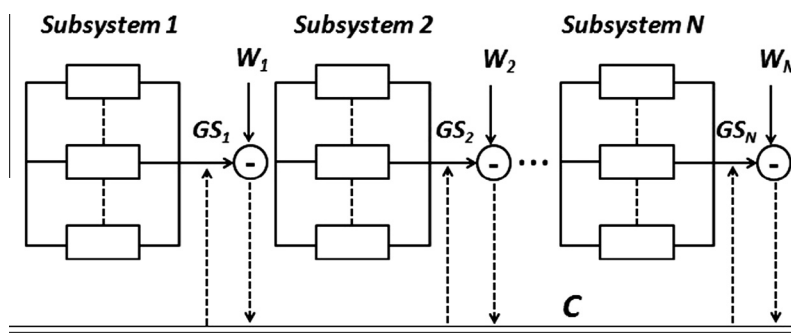

Fig. 1. Series-parallel system with common bus performance sharing.

Download English Version:

<https://daneshyari.com/en/article/1134196>

Download Persian Version:

<https://daneshyari.com/article/1134196>

[Daneshyari.com](https://daneshyari.com)