



# Performance evaluation and optimization of a novel solar-ground source heat pump system



Qiang Si<sup>a,\*</sup>, Masaya Okumiya<sup>b</sup>, Xiaosong Zhang<sup>a</sup>

<sup>a</sup> Southeast University, Nanjing, China

<sup>b</sup> Nagoya University, Nagoya, Japan

## ARTICLE INFO

### Article history:

Received 15 May 2013

Received in revised form 7 August 2013

Accepted 18 November 2013

### Keywords:

Solar-ground source heat pump

System simulation

Optimizations of design

Operation strategy

Performance evaluation

## ABSTRACT

This paper presents a novel solar-ground source heat pump system (SGSHPS) designed for an office building in Beijing for heating, cooling, and producing domestic hot water. An operation strategy of the system in transition seasons is proposed to keep the heat pump off and connect ground heat exchanger (GHE) directly to the heat exchangers of fan coils, as indoor conditioning terminal equipment. With the simulation tool TRNSYS, the important parameters of the system were optimized and the operation strategy was shown to be feasible. Two mainstream operation plural strategies in winter were analyzed and compared, and the system with GHE and solar collectors installed in series (SGSHPS(s)) showed better performance than SGSHPS(r) in cold regions.

© 2013 Elsevier B.V. All rights reserved.

## 1. Introduction

The use of renewable energy is an important substitution of fossil-non-renewable energy sources. The energy efficiency contributes to energy conservation in buildings. The ground source heat pump (GSHP) uses the underground shallow soil as cool and heat source, which is different from the traditional air-source heat pump. Because the temperature of underground soil stays relatively stable, even in the winter of cold regions soil can maintain higher temperature than the atmospheric environment. So the ground source heat pump has higher energy efficiency than an air source heat pump. But because of the imbalance between annual heating and cooling loads of buildings, after long-term operation, ground source heat pump system will inevitably cause variations of soil temperature, and this will influence energy efficiency and stability of the system. Furthermore, in the winter in cold regions, long-term operation will cause the heat pump to work at a too low evaporation temperature, even to shut down. On the other hand, because solar energy is a kind of inexhaustible, safe, clean, and non-polluting renewable energy, the use of solar energy is an important way to ease the energy and environmental crisis. However, because

terrestrial locally available solar energy is influenced by seasons and weather, there are limitations in various types of solar energy heat utilization technologies.

A combination system with two kinds of renewable energy, named the solar-ground source heat pump system (SGSHPS) is gaining popularity and attention in the world, because of its better operating efficiency and functional diversification [1,2]. The system utilizes a ground heat exchanger as heat storage, and effectively overcomes the decline of system efficiency and stability caused by intermittent and unstable solar energy, and imbalance of annual cooling and heating loads. SGSHPS is a large-scale method of utilization of renewable energy, and it has great potential. In recent years, many domestic and foreign scholars have researched SGSHPS design, simulation, and optimization with in-depth discussions. Gong tested the operating performance of systems of SAHPS, GSHPS, and SGSHPS in Tianjin, and the results showed: the average heating rates and COP of the three systems were similar, but SGSHPS had the best stability [3]. Elisabeth used TRNSYS to simulate the residential SGSHPS, it was pointed out that the best design is using solar collectors to produce domestic hot water in summer, and recharge ground heat exchanger in winter for the regions with mild climate such as Sweden [4]. Wang designed GSHPS and SGSHPS according to the load demands of different floors of buildings, and compared system performance, then proposed the optimization plan [5]. In this paper, the authors designed SGSHPS including fan coils for an office building in Beijing according to load demands. The important parameters of the operating system were optimized. An operation strategy of the system in transition seasons, to keep the heat pump off and connect GHE

\* Corresponding author at: Room 2217, Huiyan North Building, Science and education city, Changwuzhong Road No. 801, Changzhou City, JiangSu Province, 210096, China. Tel.: +81 158 61862301; fax: +81 0528355598.

E-mail addresses: [mervyns@126.com](mailto:mervyns@126.com) (Q. Si), [okumiya@davinci.nuac.nagoya-u.ac.jp](mailto:okumiya@davinci.nuac.nagoya-u.ac.jp) (M. Okumiya), [rachpe@seu.edu.cn](mailto:rachpe@seu.edu.cn) (X. Zhang).

### Nomenclature

$T_{soil}$	Average temperature of soil ( $^{\circ}\text{C}$ )
COP	Coefficient of performance
$COP_{sys}$	Coefficient of performance of whole system
$Q_{cool}$	Cooling load in summer of building (kW)
$Q_{heat}$	Heating load in winter of building (kW)
$Q_{fancoil}$	Heating or cooling load processed by fan coil (kW)
$T_{indoor}$	Indoor temperature of building ( $^{\circ}\text{C}$ )
$T_{inlet}$	Inlet temperature ( $^{\circ}\text{C}$ )
$T_{outlet}$	Outlet temperature ( $^{\circ}\text{C}$ )
$E$	Power consumption (kW)
$A_{solar}$	Solar collector area ( $\text{m}^2$ )
$W_{all}$	Total electrical energy consumed (kWh)

### Subscript

c	Collector
fc	Fan coil
GHE	Ground heat exchanger
HP	Heat pump
n	Normal SGSHPS
o	Optimized SGSHPS(s)
r	SGSHPS (r)
s	SGSHPS (s)

directly to the heat exchangers of fan coils, was proposed. Two mainstream operation strategies in winter were analyzed and compared.

## 2. System description and operation strategy

The office building selected for the proposed study is located in Beijing. The building has  $300\text{ m}^2$  living area. As the specification for air-conditioning of an office building, from morning 8:00 to evening 18:00, the indoor temperature of the building is set at  $18^{\circ}\text{C}$  in heating and  $26^{\circ}\text{C}$  in cooling period.

Two types of SGSHPS designed for the office building are shown in Figs. 1 and 2. The SGSHPS illustrated in Fig. 1, in which ground heat exchanger and solar collectors are installed in series, is called SGSHPS(s) in the following text.

In SGSHPS(s), the order of solar collectors and GHE has two options: A. When working, fluid first flows through GHE, then enters solar collectors, solar collectors can reheat the working fluid heated by GHE. COP of heat pump will be improved in short time. But the load on soil will be great, and the soil temperature will decrease rapidly, which causes COP of the whole system to decrease rapidly after long-term operation. B. Working fluid first flows through solar collectors, then enters GHE. When solar energy

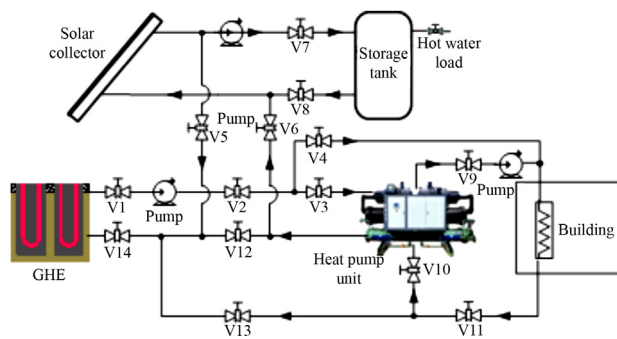

Fig. 1. Schematic of SGSHPS(s).

is abundant and heating capacity of solar collector is greater than heating load of building, this operation mode can deliver surplus solar thermal energy to underground soil and improve the recovery rate of soil temperature. But efficiency of mode B is slightly lower than that of mode A. In the literature [6], the study showed if efficiency of solar collectors was influenced little by environmental parameters, efficiency of mode B was almost the same as mode A, and performance of heat pump and soil temperature can remain more stable. Therefore, mode B is more reasonable when the technology of solar collector is mature and the collection efficiency can remain stable.

Fig. 2 illustrates another kind of SGSHPS. In this system solar collectors store solar heat collected in daytime in a storage tank, and release it to recharge GHE at night to restore soil temperature. This system is called SGSHPS(r) in the following text.

The operation strategies of these two kinds of SGSHPS systems were different in the winter heating period, while they were the same in other seasons: in summer GHE, heat pump and fan coil were utilized for cooling. Solar collectors were connected to storage tank to produce domestic hot water. In transition seasons, when fan coils need to be turned on to satisfy the cooling or heating load of the building, sometimes the load is smaller than that of summer and winter. It will squander excess power to turn on the heat pump. So we proposed a novel operation strategy to meet the demands for air conditioning in transition seasons: the heat pump will be kept off, and only the circulation pump will be used to transport the working fluid to the heat exchangers of fan coils directly after it exchanges heat with GHE. This operation strategy delayed the start of the heat pump, and reduced annual operating time of the heat pump. So the energy consumption was effectively reduced. Now the annual operation strategy of the two systems is summarized in Table 1.

## 3. Simulation program and evaluation methods

### 3.1. Simulation models of the systems

In this paper, TRNSYS 17 was used to simulate and analyze the systems. The characteristic of the software is modular analysis. Any thermal energy transfer system is divided into a number of modules. Every module performs a specific function: water heater module, single-temperature field analysis module, solar collector module, output module, etc. Users call the modules with specific functions, input the parameters, and call the control modules to input the operation strategy. Then these modules can simulate certain systems, finally the results of transient simulation can be output and analyzed. TRNSYS is suitable for simulating systems such as SGSHPS which are complex, and have various conditions and control strategies. Figs. 3 and 4 illustrate the programs of SGSHPS(s) and SGSHPS(r).

Type 557a was adopted as the simulation model for the vertical U-tube ground heat exchanger that interacts thermally with the ground, and Type 1b was adopted to model the flat-plate solar collector. The flow diverters modeled by Type 11f and mixers modeled by Type 11h were used for switching between the heat sources (solar thermal and geothermal energy) and heating components to implement the proposed operating strategies. For example, in Fig. 3, when the outlet to the storage tank of Flow diverter-3 and the outlet to Tee piece-4 of Flow diverter-4 are closed, and the outlet to Tee piece-4 of Flow diverter-3 and the outlet to Tee piece-2 of Flow diverter-4 are open, the solar collectors and GHE will be operating in series. The on/off signals were generated by series of Type 14s which were time dependent forcing function and have a behavior characterized by a repeated pattern. The practical operation of the

Download English Version:

<https://daneshyari.com/en/article/263068>

Download Persian Version:

<https://daneshyari.com/article/263068>

[Daneshyari.com](https://daneshyari.com)