

Adaptive Polar Fuzzy logic based Load Frequency Controller



D.K. Chaturvedi^{a,*}, Rahul Umrao^a, O.P. Malik^b

^aThe Department of Electrical Engineering Faculty of Engineering, Dayalbagh Educational Institute, Dayalbagh, Agra 282005, India

^bDept. of Electrical and Computer Engineering, University of Calgary, Calgary, AB, Canada

ARTICLE INFO

Article history:

Received 19 August 2013

Accepted 10 October 2014

Available online 19 November 2014

Keywords:

Load Frequency Control

Adaptive Polar Fuzzy Controller

Power systems

Fuzzy system

Genetic algorithms

ABSTRACT

Performance of a Fuzzy logic controller is dependent on sufficient and accurate knowledge base. As the number of rules in a knowledge base increases, its complexity increases which in turn affects the computation time and memory requirements. To overcome these problems, a Polar Fuzzy logic controller is proposed. The aim of the Polar Fuzzy Controller (PFC) is to restore the frequency and tie-line power in a smooth way to its nominal value in the shortest possible time if any load disturbance is applied to any area of power system. In this paper, the PFC is made adaptive using a Genetic algorithm-fuzzy system (GAF) approach. Performance of the simple PFC and adaptive PFC using GAF is compared with fuzzy and conventional PI controllers on a three area system.

© 2014 Elsevier Ltd. All rights reserved.

Introduction

The large-scale power systems consist of interconnected control areas. In these large scale interconnected power systems disturbance in one area can cause oscillations and also affect the frequency of other areas. These oscillations sometimes create a big problem in the system and may lead to complete blackout. Hence, Load Frequency Control (LFC) problem is very important to keep the system frequency and the inter-area tie line power as close as possible to the scheduled values [1]. The mechanical input power to the generators is changed to control the frequency of electrical power and to maintain the power exchange between the areas as scheduled. A well designed power system should cope with these changes on the load side and high level of power quality can be achieved by maintaining both voltage and frequency within limits [2,3].

The primary objective of LFC is to maintain each unit's generation at the most economic value [4]. Several strategies for LFC have been proposed in the past, although a majority of these studies have considered the conventional PI controllers [5]. Advantages

of PI controllers are: simple in structure, no long-term error, and normally provide highly responsive control system. The predominant weakness is that PI controllers often produce excessive overshoot to a step command [6–11].

Therefore, several intelligent control techniques for LFC are reported in the literature [6]. Fuzzy logic controller (FLC) is based on a fuzzy logic system which is much closer to human thinking and natural language than classical logic systems [2–5,11–13]. The performance of FLC is dependent on the knowledge base i.e. number of rules, range of membership functions and their overlapping etc. To overcome these drawbacks, an adaptive Polar Fuzzy Controller is proposed.

Fuzzy logic controller

The Conventional Fuzzy logic controller for LFC, shown in Fig. 1, consists of three functions: fuzzification, approximate reasoning and defuzzification blocks. Five triangular membership functions are taken for both input, i.e. frequency deviation Δf and integral of frequency deviation $\int \Delta f$, and output of fuzzy controller, u . The Fuzzy Associate Memory (FAM) table given in Appendix (Table A1) shows the rules of fuzzy logic controller for LFC. It is the fuzzy relationship between input and output in the form of rules. The twenty-five-rules are used for FLC, which indeed gives a consistently better performance than the conventional controller for LFC, but the mathematical operation with several rules is rather complex and time consuming.

Abbreviations: GA, Genetic algorithm; GAF, adaptive GA with fuzzy system; RCGA, real coded GA; PFC, Polar Fuzzy Controller; FLC, Fuzzy logic controller; L, M, H, Low, Medium and High Linguistic Value; FAM, Fuzzy Associative Memory; P_c , crossover probability; P_m , mutation probability; P , Population Number; P_{max} , Maximum number of Population; G , Generation Number; G_{max} , Maximum number of Generations; LFC, Load Frequency Control.

* Corresponding author.

E-mail addresses: dkc.foe@gmail.com (D.K. Chaturvedi), rahulumrao@gmail.com (R. Umrao).

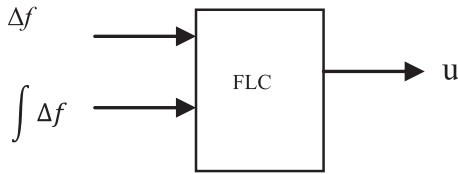

Fig. 1. Conventional Fuzzy logic controller for LFC.

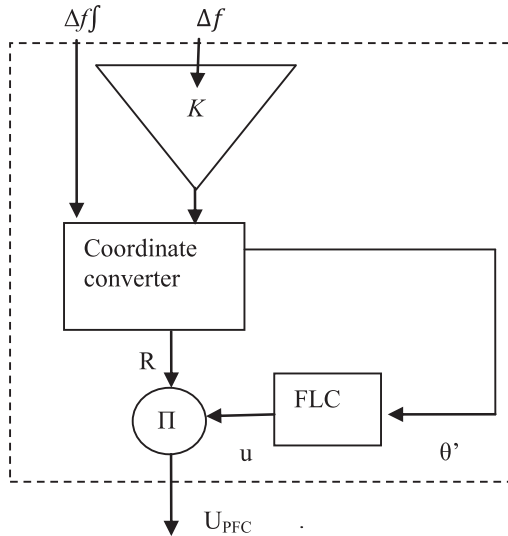

Fig. 2. Block diagram of proposed Polar Fuzzy logic controller.

Table 1
Defining Fuzzy sets for PFC.

		Membership at variable value	
Variables	Fuzzy sets	Zero	One
Input (θ)	Low (L)	0° and 400°	200°
	High (H)	250°	0° and 400°
Output (u)	Negative (N)	-1 and -0.5	-0.75
	Positive (P)	0.5 and 1	0.75

Table 2
FAM tables for controlling P_c .

NCF →	L	M	H
HF ↓			
L	H	H	H
M	H	M	
H	H	M	

Polar Fuzzy Controller (PFC)

In conventional PI controller and also in fuzzy controller two inputs (i.e. deviation in power system frequency, Δf , and the integral of frequency deviation, $\int \Delta f \cdot dt$, are used to calculate control action. But in the case of PFC these inputs are converted to polar coordinates and only one input (angle) is used to calculate output using FLC and magnitude is multiplied in the FLC output [14] as shown in Fig. 2. Hence PFC is very simple and uses only two rules.

Table 3
FAM table for controlling P_m .

NCF →	L	M	H
HF ↓			
L	L	L	L
M	L	M	
H	L	M	

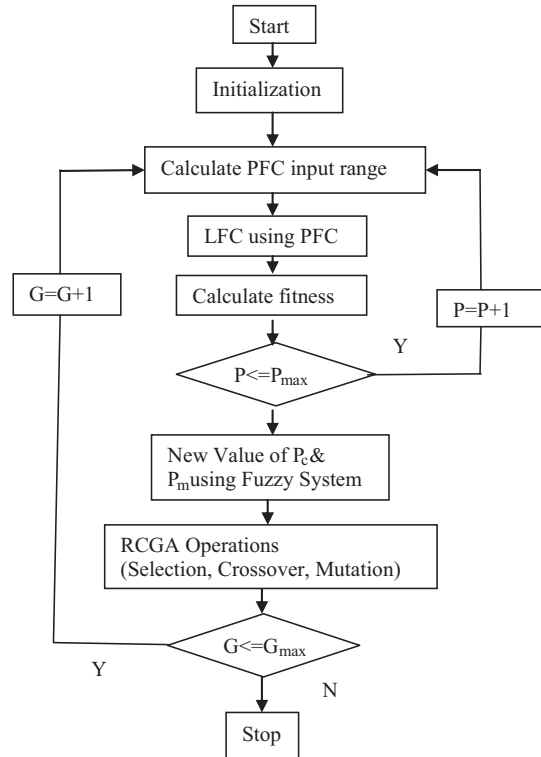

Fig. 3. Flow chart of adaptive PFC using GAF.

Details of membership functions of input and output are given below:

Two fuzzy membership functions (triangular in shape) are defined for input angle θ and output u as given in Table 1.

Fuzzy Input : Angle θ (degrees) = {Low (L) High (H)}

Fuzzy sets for output $u :=$ {Positive (P), Negative (N)}

In Polar Fuzzy logic based controller, there is no need to use two separate input gains for Δf and $\int \Delta f \cdot dt$, because only one input, the angle, that depends on the ratio of the properly scaled inputs (i.e. Δf and $\int \Delta f \cdot dt$) is used. Thus, only one gain, K , is considered in Δf or $\int \Delta f \cdot dt$. In this case gain is used with integral of frequency deviation $\int \Delta f \cdot dt$. The scaling factor K decides as to which variable, frequency deviation or integral of frequency deviation, has more weight in the magnitude R . The maximum and minimum control action is fixed at angles 45° and 135° respectively, because at 45° Δf and $\int \Delta f \cdot dt$ both are positive and produce maximum disturbance to system and vice versa at 135°.

The required control strategy can be described as:

Download English Version:

<https://daneshyari.com/en/article/398622>

Download Persian Version:

<https://daneshyari.com/article/398622>

[Daneshyari.com](https://daneshyari.com)