



Vibration properties of and power harvested by a system of electromagnetic vibration energy harvesters that have electrical dynamics



Christopher G. Cooley

Department of Mechanical Engineering and Energy Processes, Southern Illinois University Carbondale, 1230 Lincoln Dr., Carbondale, IL 62901, USA

ARTICLE INFO

Article history:

Received 10 September 2016

Received in revised form 8 February 2017

Accepted 23 February 2017

Keywords:

Vibration energy harvesting

Electromechanical system

Damped vibrations

Electromagnetic device

ABSTRACT

This study investigates the vibration and dynamic response of a system of coupled electromagnetic vibration energy harvesting devices that each consist of a proof mass, elastic structure, electromagnetic generator, and energy harvesting circuit with inductance, resistance, and capacitance. The governing equations for the coupled electromechanical system are derived using Newtonian mechanics and Kirchhoff circuit laws for an arbitrary number of these subsystems. The equations are cast in matrix operator form to expose the device's vibration properties. The device's complex-valued eigenvalues and eigenvectors are related to physical characteristics of its vibration. Because the electrical circuit has dynamics, these devices have more natural frequencies than typical electromagnetic vibration energy harvesters that have purely resistive circuits. Closed-form expressions for the steady state dynamic response and average power harvested are derived for devices with a single subsystem. Example numerical results for single and double subsystem devices show that the natural frequencies and vibration modes obtained from the eigenvalue problem agree with the resonance locations and response amplitudes obtained independently from forced response calculations. This agreement demonstrates the usefulness of solving eigenvalue problems for these devices. The average power harvested by the device differs substantially at each resonance. Devices with multiple subsystems have multiple modes where large amounts of power are harvested.

© 2017 Elsevier Ltd. All rights reserved.

1. Introduction

Vibration energy harvesting research is reviewed in Refs. [1–4].

Vibration energy harvesting from electromagnetic devices has been investigated in Refs. [5–27]. Stephen [7] analyzed the dynamic response of and power generated by devices with a single proof mass and purely resistive electrical load. When operated near resonance, these devices harvest maximum power when the damping from the electrical circuit equals that in the mechanical system. Mann and Sims [8] investigated the effect of coil inductance on the response and power harvested by electromagnetic vibration energy harvesters. The power generated from sinusoidal, periodic, and random excitation was determined. Mann and Sims [9] studied the nonlinear dynamics of a magnetically levitating vibration energy harvester. Yang et al. [10] experimentally investigated the energy harvested from the first three modes of a vibrating beam electromagnetic device. Mann and Owens [11] investigated the response and energy harvested by a nonlinear electromagnetic device.

E-mail address: chris.cooley@siu.edu

Trimble et al. [12] developed and analyzed a vibration energy harvester for spinning systems that experience rotational vibrations. Cammarano et al. [13] studied vibration energy harvesting from electromagnetic devices that can be actively tuned for improved performance. Elvin and Elvin [15] analytically and experimentally investigated the power generated by an electromagnetic vibration energy harvester. Their model accurately predicted the dynamic response compared to experiments for a wide range of system parameters. Daqaq [16] investigated the power harvested by bistable nonlinear electromagnetic vibration energy harvesters excited by random vibration. Tang and Zuo [17] investigated vibration energy harvesting from a dual-mass device that consists of two proof masses coupled by an electromagnetic generator or piezoelectric structure. The dual-mass device was shown to outperform comparable devices with a single mass. Vibration energy harvesting from dual-mass devices subjected to random excitation was investigated in Ref. [21]. The energy harvested from the vibration of rectangular plates with an arbitrary number of electromagnetic vibration energy harvesters was investigated by Harne [22]. He and Daqaq [23] studied vibration energy harvesting from nonlinear devices with asymmetric potential function asymmetries. Gonzalez-Buelga et al. [24] analyzed a tunable electromagnetic vibration absorber that converts the absorbed vibration into electrical power. Caruso [25] investigated the power harvested by electromagnetic vibration energy harvesters with electrical circuits that have inductance, capacitance, and resistance. When adaptively tuned at each frequency, this device has broadband energy harvesting ability. Tang et al. [28] investigated the energy harvesting and vibration damping abilities of shunted tuned mass dampers. Many of these studies focus on maximizing the power harvested by the devices. None of these works investigate the vibration properties of electromagnetic vibration energy harvesters, which is a focus of this work. Most of the electromagnetic devices referenced above are designed to power a single electrical load. This work analyzes electromagnetic devices that can simultaneously power multiple electrical loads.

Piezoelectric stack vibration energy harvesting devices have been investigated in Refs. [29–33]. Vibrating beam devices with piezoelectric material layers have been investigated in Refs. [30,34–40], for example. Many more can be found in the review articles in Refs. [1–4]. Piezoelectric vibration energy harvesters with multiple proof masses and degrees of freedom are investigated in Refs. [41–43].

This study investigates the vibration properties of electromagnetic vibration energy harvesters. The governing equations are derived for devices with an arbitrary number of energy harvesting subsystems, which each consist of a proof mass, elastic structure, and an energy harvesting circuit with inductance, resistance, and capacitance. The device's eigenvalue problem is cast in matrix operator form, which makes clear the qualitative nature of the vibration of these devices. Numerical results are generated for example devices with one and two subsystems. Dynamic response predictions are compared to natural frequency and vibration mode results obtained from the eigenvalue problem. The power harvested from sinusoidal base excitation is determined for a wide range of excitation frequencies. The different resonances of the device are compared to determine the preferred modes for energy harvesting applications. The natural frequencies, dynamic response, and power harvested are calculated for a wide range of electric circuit model parameters.

2. Analysis

2.1. Analytical model

A schematic of the electromagnetic vibration energy harvester is shown in Fig. 1. The device consists of N energy harvesting subsystems. Each subsystem has a proof mass m_i ($i = 1, 2, \dots, N$) and an energy harvesting circuit. Adjacent proof masses are connected by (i) elastic structures that have stiffnesses k_i and equivalent viscous damping coefficients c_i and (ii) electromagnetic generators with electromechanical coupling coefficients κ_i . The first proof mass is attached to a vibrating host

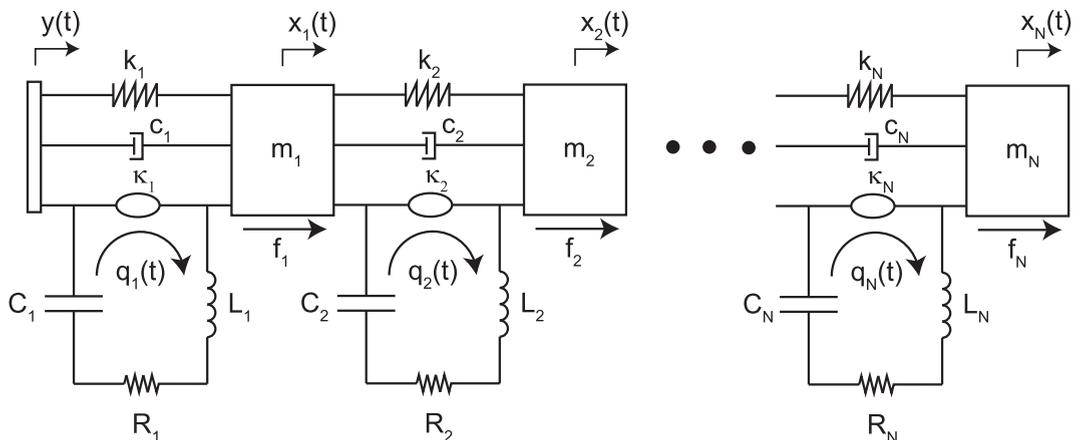

Fig. 1. Schematic of a system of electromagnetic vibration energy harvesting devices.

Download English Version:

<https://daneshyari.com/en/article/4976937>

Download Persian Version:

<https://daneshyari.com/article/4976937>

[Daneshyari.com](https://daneshyari.com)