



Adaptive control schemes for improving dynamic performance of efficiency-optimized induction motor drives



Navneet Kumar^{a,*}, Thanga Raj Chelliah^{a,1}, S.P. Srivastava^{b,2}

^a Department of Water Resources Development and Management, Indian Institute of Technology, Roorkee (IIT-Roorkee), Uttarakand 247667, India

^b Department of Electrical Engineering, Indian Institute of Technology, Roorkee (IIT-Roorkee), Uttarakand 247667, India

ARTICLE INFO

Article history:

Received 21 May 2014

Received in revised form

20 December 2014

Accepted 20 February 2015

Available online 26 March 2015

This paper was recommended for publication by Didier Theilliol

Keywords:

Induction motors dynamics

Loss-minimization

Mine-hoist load

Model based control

Speed controller

Variable structure control

ABSTRACT

Model Based Control (MBC) is one of the energy optimal controllers used in vector-controlled Induction Motor (IM) for controlling the excitation of motor in accordance with torque and speed. MBC offers energy conservation especially at part-load operation, but it creates ripples in torque and speed during load transition, leading to poor dynamic performance of the drive. This study investigates the opportunity for improving dynamic performance of a three-phase IM operating with MBC and proposes three control schemes: (i) MBC with a low pass filter (ii) torque producing current (i_{qs}) injection in the output of speed controller (iii) Variable Structure Speed Controller (VSSC). The pre and post operation of MBC during load transition is also analyzed. The dynamic performance of a 1-hp, three-phase squirrel-cage IM with mine-hoist load diagram is tested. Test results are provided for the conventional field-oriented (constant flux) control and MBC (adjustable excitation) with proposed schemes. The effectiveness of proposed schemes is also illustrated for parametric variations. The test results and subsequent analysis confer that the motor dynamics improves significantly with all three proposed schemes in terms of overshoot/undershoot peak amplitude of torque and DC link power in addition to energy saving during load transitions.

© 2015 ISA. Published by Elsevier Ltd. All rights reserved.

1. Introduction

Three-Phase IMs are the most extensively used machines in various electrical drives due to their reliability, ruggedness and relatively lower cost. Around 70% of all industry loads, on a utility, are represented by IMs [1]. Due to rapidly increasing electricity prices, it becomes of prime penchant for researchers that awareness be paid for efficient optimization of IMs [2]. Generally, for rated speed and torque, IM shows high efficiency. However, at light loads considerable reduction in motor efficiency is observed due to increase in motor iron losses [3,4]. Therefore, to optimize efficiency of the motor at partial loads, it is essential to obtain such flux levels that maintain a balance between iron and copper losses [4]. Motor excitation, a monotone increasing function of the load, can improve both, the motor efficiency as well as the power factor. To achieve this goal, IM should either be fed through an inverter or should be redesigned [5].

Many loss-minimization strategies have been developed for adjusting flux levels in accordance with load(s) and speed(s). The various loss-minimization techniques have been reviewed very

well in [6]. Principally, these techniques can be divided into two categories: online search controller and loss-model-based controller. Input power is measured in online search controller and flux level is changed until the minimum input power is achieved. The search strategies are slow convergent but completely insensitive to parametric variations caused by temperature and saturation. The loss-model-based controllers estimate the optimum flux level [7–9] by using loss-model of the machine. They are normally fast convergent than online search methods but are sensitive to parametric variations. The sensitivity of MBC for parametric variations are discussed in [10]. Though, knowing accurate model parameters is very difficult especially if the system is flexible [11]. However, loss-model-based controllers are more suitable to vector controlled IM drives where the motor parameters (torque and speed) are needed to be controlled [12] but these controllers may cause higher pulsations in torque and flux [12,13] during load transitions.

The MBC implemented in a vector controlled IM drive (shown in Fig. 1) determines the optimal air-gap flux from speed, stator current and IM loss model. The internal part of control algorithm may be vector or scalar. Stochastic techniques may be used for searching optimal flux level corresponding to desired torque from the loss model of the IM. In literature, several strategies have been reported by many researchers to minimize losses in IM using different variables. Some algorithms use optimal slip [14,15], rotor

* Corresponding author. Tel.: +91 9456993646.

E-mail addresses: teenvan2002@gmail.com (N. Kumar), thangaraj@ieee.org (T. Raj Chelliah), satyafee@iitr.ernet.in (S.P. Srivastava).

¹ Tel.: +91 1332 285554.

² Tel.: +91 9411544198.

Nomenclature

R_s	Stator resistance
R_r	Rotor resistance
L_m	Magnetizing inductance
τ_r	Rotor time constant
\bar{s}	Laplace coefficient
ω	Speed
T_e	Electromagnetic torque
ϕ_m	Air-gap flux
I_s	Stator current
I_r	Rotor current
I_m	Magnetizing current
s	Slip

as	Slip frequency
P_c	Total Copper losses
P_i	Iron losses
P_{str}	Stray losses
P_m	Mechanical losses
P_{loss}	Total losses
k_e	Eddy current coefficient
k_h	Hysteresis coefficient
C_{fw}	Mechanical loss coefficients
C_{str}	Stray loss coefficient
K_1, K_2	Switching losses coefficients
i_{ds}^*	Flux producing current
i_{qs}^*	Torque producing current
*	Reference

flux [5,9,16–19], input power [9,20,21] and input voltage [22,23] as the control variable.

In constant flux operation (conventional vector control), machine dynamics around the reference points are maintained by several controllers, viz. sliding mode control [24,25] neural network [26,27] and fuzzy controls [21,28–30]. The MBC can be implemented with vector controlled IM drive with help of micro-controllers, Digital Signal Processor (DSP) and dSPACE controller. In the operation of MBC, sudden reduction in flux followed by sudden reduction in flux producing current (i_{ds}^*) results overshoot/undershoot in load torque and DC link power, during variable load/speed operation [31,32].

In this study, three control schemes are proposed to improve dynamic performance of the motor during load transition, in terms of overshoot/undershoot peak amplitude. These schemes can be easily implemented with MBC with small additional cost. In the first scheme, first-order low-pass filter is used for smooth adjustment of the output of MBC whereas an i_{ds}^* in conventional MBC is step changed. This concept is already discussed in search control, one of

the energy optimal controllers (physics based) [33]. In second scheme, the negative value of the torque producing current (i_{qs}^*) is injected to its original signal for small duration after load transition that leads i_{qs}^* to steady state quickly. In the third scheme, VSSC is used instead of conventional PI speed controller. The block diagram of the drive with control schemes is shown in Fig. 1. The i_{ds}^* generated by MBC and the i_{qs}^* generated by speed controller (conventional PI speed controller/VSSC) is converted into three-phase quantities. Inverter triggering pulses are generated by PWM current controller according to the error between reference and actual currents. In addition, the pre and post operations of MBC at load transition points are also discussed.

The organization of this study is as follows. Section 2 briefly explains the mine hoist load, Section 3 shows method for efficiency optimization, Section 4 derives the loss model of the IM, objective function and optimal flux with respect to variable load/speed, Section 5 discusses about the proposed techniques to improve the dynamics, Section 6 presents the simulation results of 1-hp motor, Section 7 represents energy consumption during load transitions and finally the paper concludes in Section 8.

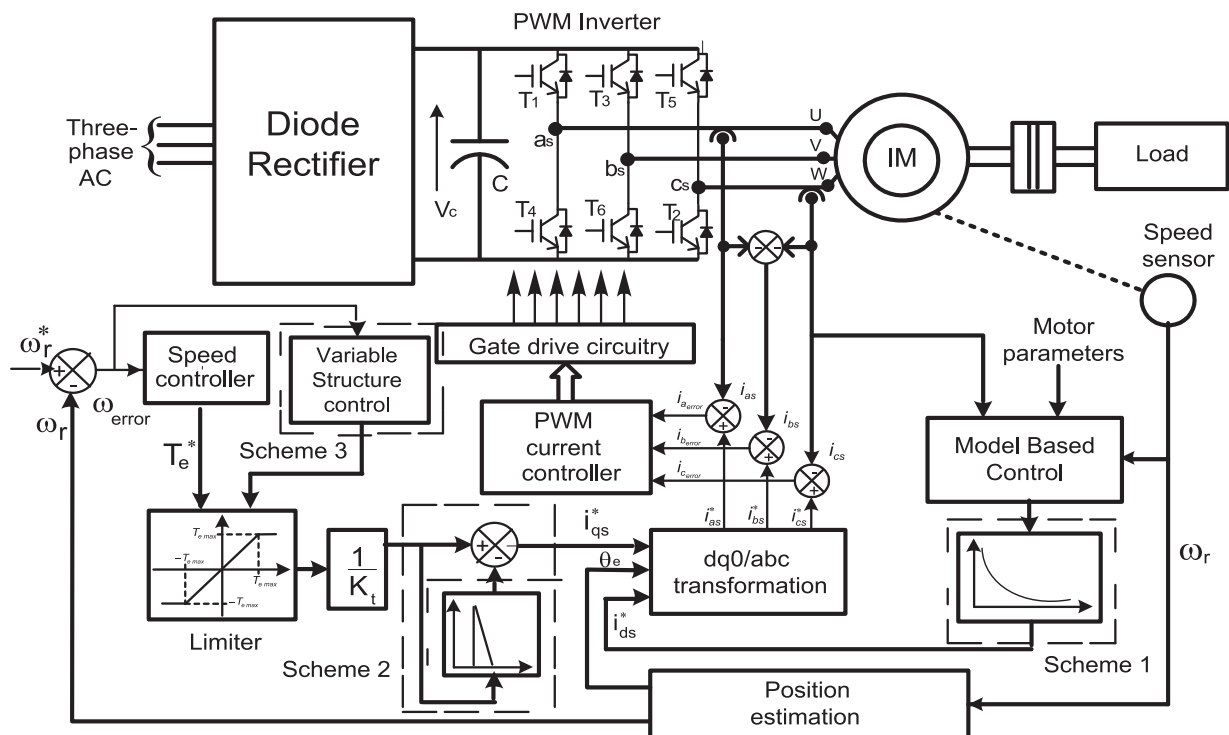

Fig. 1. MBC based vector controlled IM with proposed schemes.

Download English Version:

<https://daneshyari.com/en/article/5004439>

Download Persian Version:

<https://daneshyari.com/article/5004439>

[Daneshyari.com](https://daneshyari.com)