



# Lifting peripheral fortunes: Upgrading transit improves spatial, income and gender equity in Medellín



Blanca Fernandez Milan<sup>a,b,1</sup>, Felix Creutzig<sup>a,b,\*</sup>

<sup>a</sup> Mercator Research Institute on Global Commons and Climate Change (MCC), Torgauer Str. 12 – 15, 10829 Berlin, Germany

<sup>b</sup> Department Economics of Climate Change, Technical University of Berlin, Straße des 17. Juni 145, D-10623 Berlin, Germany

## ARTICLE INFO

### Keywords:

Transit-oriented development  
Quality of life  
Social capital  
Participatory planning  
Urban equity

## ABSTRACT

New transit development often try to provide low-carbon mobility, and improve accessibility. However, it is often unclear who profits most from new transit developments, whether these transit developments can improve equity, and if yes, in which dimensions. Here we study the change in quality of life, instrumentalised as perceived and measured social capital, socio-economic well-being, and quality of public infrastructure after transit developments in Medellín, Columbia. We make use of a detailed questionnaire of 187 questions from 2009 and 2012, aggregate responses into 14 indicators, and compare changes in quality of life between three transit developments zones (comunas), three non-intervention zones, and between income levels and gender. We find that equity improved overall across geographical zones, income, and gender, even as changes in specific quality of life dimensions varied. Our results demonstrate that well-designed transit interventions and participatory planning processes can make cities not only more climate friendly but also more equal.

## 1. Introduction

Cities and municipalities have to pragmatically navigate multiple challenges and demands. Surprisingly often, urban development and redevelopment are structured around transport systems, including the build-up of European cities, like Berlin and London, around a new subway system, and the North-American suburbanization along highways (Cervero & Landis, 1995; Wolf, 1994). While transit-oriented development is as old as the streetcar, the modern usage was conceptualized by Peter Calthorpe in the North American context (Calthorpe, 1993). Successful examples and model projects include the transit systems in Curitiba, Brazil (Rabinovitch & Leitman, 2004), Arlington, and Denver, both United States (Ratner & Goetz, 2013), and Freiburg, Germany (Creutzig, Mühlhoff, & Römer, 2012). Worldwide, municipalities demonstrate an increasing or re-emerging interest in public transport and transit-oriented development (TOD) because it provides economic, social, and environmental benefits (Belzer & Autler, 2002; Bongardt, Breithaupt, & Creutzig, 2010; Bongardt et al., 2013; Creutzig & He, 2009; Curtis, Renne, & Bertolini, 2009; Newman & Kenworthy, 1999; Renne, 2008). However, most of these studies focus on the climate, environment, and health benefits of transit interventions. But - while less well studied - TOD also can shape citizen's quality of live and social interactions (Dempsey,

Brown, & Bramley, 2012; Glaeser & Gottlieb, 2006). This issue is of rising and profound importance because of two global trends. First, the rising global inequality (Piketty, 2014) leaves its particular footprint on cities, often discussed as gentrification (Holm, 2006; Kahn, 2007). Gentrification often pushes out the poor to the periphery of cities, and to districts with less transport access. Second, climate change is likely to hit the urban poor and women most, but also urban climate mitigation strategies will impact different segments of the population unequally (Reckien et al., 2017). These trends emphasize the value of identifying opportunities to render cities and the urban landscape more equal.

We use the case of Medellín (Colombia) to evaluate the social benefits of participatory TOD. Medellín has been widely used as a benchmark for its transit development in general and its urban planning in marginalized areas in particular (Blanco & Kobayashi, 2009; Brand, 2010; Dávila, 2014; Echeverri & Orsini, 2011; Fukuyama & Colby, 2011; Hylton, 2007). Empirical evidence demonstrates a reduction of violence and transport emissions (Cerdeña et al., 2012; Dávila, 2012a), but there is a lack of understanding how TOD influences equity and perceived quality of life in general. Our methods – based on data from the annual citizen survey - allow us to evaluate citizen's changes in socioeconomic variables, their perception of public interventions, and their social capita for two comparison groups according to their modal changes. By comparison, we evaluate equity outcomes for all variables across

\* Corresponding author at: Mercator Research Institute on Global Commons and Climate Change (MCC), Torgauer Str. 12 – 15, 10829 Berlin, Germany.

E-mail addresses: [fernandez@mcc-berlin.net](mailto:fernandez@mcc-berlin.net) (B.F. Milan), [creutzig@mcc-berlin.net](mailto:creutzig@mcc-berlin.net) (F. Creutzig).

<sup>1</sup> Both authors contributed equally.

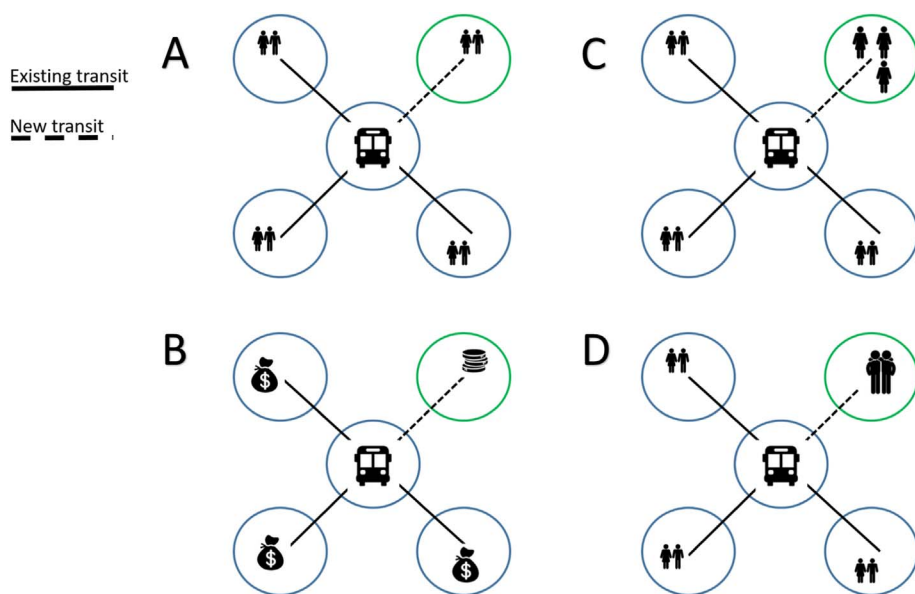

Fig. 1. Theoretical equity effects of transit-oriented development. A) Horizontal spatial equity: adding a new transit connection provides equal access to all areas. B) Vertical economic equity: the new transit line improves access specifically for the less well-off. C) Vertical gender equity: the new transit line helps women specifically. D) Vertical social equity: transit-oriented development improves the social capital of residents.

geographical zones, income groups, and gender.

In the following, we refer to the transit developments in Medellín as transit-oriented (re)-development, or TOD. TOD is often defined as an integrated urban development focusing on increased usage of public transport in area of plus or minus of 800 m around transit stations (Calthorpe, 1993; Dittmar & Poticha, 2004). Here we make somewhat wider use of that concept and refer to TOD as an integrated urban development concept, in which urban spaces and transit options are designed to increase the usage of low-carbon intensity transport modes while improving accessibility (Belzer & Autler, 2002; Curtis et al., 2009; Nahlik & Chester, 2014; Newman & Kenworthy, 1999; Rahul & Verma, 2013; Vickerman, 2008).

The structure of the paper is as follows: Section 2 reviews the literature on TOD and social capital, Section 3 introduces the case of Medellín; Section 4 explains the methods and data on which our research relies. Section 5 reports the main results, which are then discussed in Section 6 together with the conclusion remarks.

## 2. Social capital in transit development – an overview

Transit-oriented development can generate a number of different benefits. By modifying urban form and inducing modal shift, it supports climate change mitigation and can reduce congestion (Creutzig, 2014; Kahn Ribeiro et al., 2012; Lohrey & Creutzig, 2016; Sims et al., 2014), reduce health costs (Nahlik & Chester, 2014; Newman & Kenworthy, 1999; Rahul & Verma, 2013; Vickerman, 2008) but also household expenditures of passenger and goods transportation (Belzer & Autler, 2002; Newman & Kenworthy, 1999). If mixed land use is integral part, transit development may also enhance natural ecosystem's quality and increase location values (Dubé, Rosiers, Thériault, & Dib, 2011; Hasibuan, Soemardi, Koestoer, & Moersidik, 2014; Nahlik & Chester, 2014; Rahul & Verma, 2013). Moreover, well-designed transit systems attract additional investment, create jobs, and expand the catchment urban area, ultimately enhancing the regional competitiveness of the city (Knowles, 2012). However, the social and equity perspective of urban transport development has been less studied.

The majority of studies on equity and transit-oriented development, or transit projects in general, have focused on the North America setting, reflecting the origin of authors (e.g., (Cervero, 2004; Deakin, 2001; El-Geneidy et al., 2016). These studies reflect the North American land-use transport setting that is dominated by expansive cities and highway systems (Anas, Arnott, & Small, 1998; Gillham, 2002). Segregation dynamics had given rise to impoverished downtowns (Clark,

1986; Wylie & Hammel, 2004), a dynamic that partially reversed in the last decade, reflected in tightening real estate prices in inner cities (Burayidi, 2013). In this context, inequality in access is dominated by low-income groups that cannot afford cars, and those unable to use cars, such as kids, disabled, and seniors (Garrett & Taylor, 1999). Together with segregation dynamics, improving equity in access implies a focus of serving low-income areas with public transit (Garrett & Taylor, 1999; Martin, 1998; Nelson, Sanchez, Wolf, & Farquhar, 2004). However, this is an uphill battle as car dependency implies sparse transit networks that cannot profit from economics of density and scope (Creutzig, 2014; Frank & Pivo, 1994).

Other parts of the world have vastly different land-use transport settings, and hence, other challenges. However, studies on equity in transport are not frequent (but see, e.g. studies on Cali, Columbia (Delmelle & Casas, 2012); Copenhagen, Denmark (Kaplan, Popoks, Prato, & Ceder, A. (Avi), 2014), and Perth, Australia (Ricciardi, Xia, & Currie, 2015). More dense urban settings translate into better economics of public transit. In this context, the main equity challenge is less related to car ownership but is the spatial exclusion of areas not served by public transit. In Cali, Columbia, the provision of a bus-rapid-transit line increased access for middle income-groups but less for lower and higher income groups (Delmelle & Casas, 2012). In well-developed public transit systems, the inclusion of the physically disabled becomes a major area for equity improvement, e.g. by stairless access to transit systems (Grüber, Ackermann, & Spörke, 2011).

The literature suggests that equity improvements can be distinguished into different categories even as these are often overlapping (Kaplan et al., 2014). Horizontal equity concerns the equal provision of access for everyone; specifically spatial horizontal equity requires the equal provision of transit access to different spatial areas. In contrast, vertical equity specifically requires the improved access of those with fewer resources, such as income. However, there are additional dimensions in vertical equity. For example, women have sometimes less access to means of transport. In those situations, transit-oriented development can at least partially improve gender equity. But transit-oriented development is not only about an improvement of access. Depending on design solutions, and the process of execution (e.g., whether planning is participatory or not), transit developments can also improve the quality of the physical environment, and social capital. These different equity outcomes are conceptualized in Fig. 1.

Here we investigate all equity dimensions above, taking the provision of cable cars in Medellín as an example. Our emphasis is on the process-related outcomes, notably social capital that has previously

Download English Version:

<https://daneshyari.com/en/article/5107987>

Download Persian Version:

<https://daneshyari.com/article/5107987>

[Daneshyari.com](https://daneshyari.com)