

Fault diagnostics in power transformer model winding for different alpha values

G.H. Kusumadevi^{a,*}, G.R. Gurumurthy^{b,1}

^a *Research scholar, JAIN University, Department of Electrical & Electronics Engineering, Acharya Institute of Technology, Bangalore 560107, Karnataka, India*

^b *Department of Electrical & Electronics Engineering, The Oxford College of Engineering, Bangalore 560068, Karnataka, India*

Available online 20 June 2015

Abstract

Transient overvoltages appearing at line terminal of power transformer HV windings can cause failure of winding insulation. The failure can be from winding to ground or between turns or sections of winding. In most of the cases, failure from winding to ground can be detected by changes in the wave shape of surge voltage appearing at line terminal. However, detection of insulation failure between turns may be difficult due to intricacies involved in identifications of faults. In this paper, simulation investigations carried out on a power transformer model winding for identifying faults between turns of winding has been reported. The power transformer HV winding has been represented by 8 sections, 16 sections and 24 sections. Neutral current waveform has been analyzed for same model winding represented by different number of sections. The values of α (α' value is the square root of total ground capacitance to total series capacitance of winding) considered for windings are 5, 10 and 20. Standard lightning impulse voltage (1.2/50 μ s wave shape) have been considered for analysis. Computer simulations have been carried out using software PSPICE version 10.0. Neutral current and frequency response analysis methods have been used for identification of faults within sections of transformer model winding.

© 2015 The Authors. Production and hosting by Elsevier B.V. This is an open access article under the CC BY-NC-ND license (<http://creativecommons.org/licenses/by-nc-nd/4.0/>).

Keywords: Lightning overvoltage; Transformer model windings; Insulation failure; Neutral current; Frequency response analysis

1. Introduction

Appearance of transient overvoltages at the line terminal of HV transformer winding can cause failure of insulation of the winding. This is because voltage distribution along the length of the winding can be highly non-uniform depending on the rise time of surge voltages and also α' value of the winding. Further, there can be large voltage oscillations of various natural frequencies before the voltage distribution settle down towards steady state behaviour

* Corresponding author. Tel.: +91 9945331319.

E-mail addresses: kusumadevigh@gmail.com (G.H. Kusumadevi), rggurumurthy@yahoo.com (G.R. Gurumurthy).

¹ Tel.: +91 9845038229.

Peer review under responsibility of Electronics Research Institute (ERI).



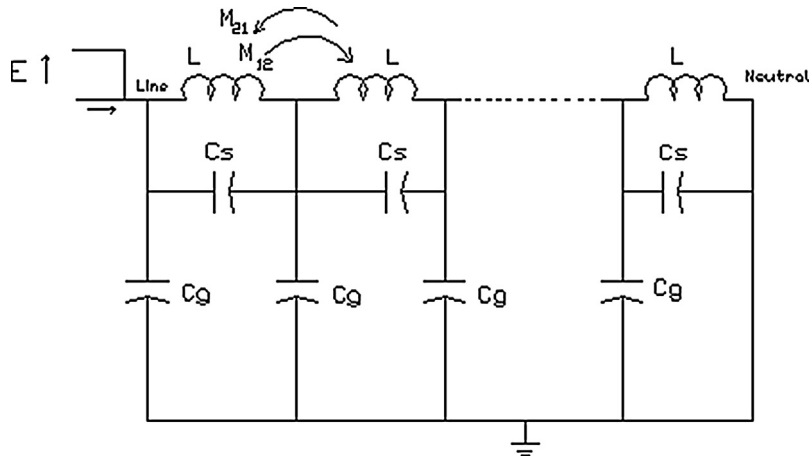

Fig. 1. Equivalent circuit of transformer winding for surge voltages.

(Blume et al., 1952; Vasutinsky, 1962; Heller and Veverka, 1968; Greenwood, 1971; Kuffel et al., 2000). It is always possible that overvoltages appearing between winding and ground and also between turns and sections of winding can cause insulation failure of winding. Generally insulation failure between winding to ground can be identified by changes occurring to the transient voltage waveform as a consequence of fault. However, in case of failure of insulation between turns and sections of winding, fault detection may be difficult due to intricacies involved in recording of measurement parameters (Ansari et al., 2009; Ansari et al., 2010; Grover, 1962; Dick and Erven, 1978; Ryszard and Bertrand, 1988). In order to investigate insulation failure between turns and sections of the winding, studies have been carried out on transformer model winding. The selected model winding has been represented as constituting of 8 sections, 16 sections and 24 sections for purposes of investigations. For each of these representation α values 5, 10 and 20 have been selected. By carrying out computer simulations of model winding, neutral current waveform have been obtained for 0.75 pu standard lightning impulse voltage (1.2/50 μ s wave shape) appearing at line terminal for winding with and without fault. Simulations have been carried using software PSPICE version 10.0.

2. Transformer model winding

For analysis of surge voltage distribution along the length of a HV power transformer winding, the winding can be represented by an equivalent circuit consisting of many similar sections as shown in Fig. 1 (Blume et al., 1952; Vasutinsky, 1962; Heller and Veverka, 1968; Greenwood, 1971). Each section is same and consists of series inductance “L” representing self inductance of winding turns of a section, mutual inductances between sections $M_{12}, M_{21}, \dots, M_{1,12} M_{12,1}, \dots$, series capacitance C_s representing inter turn insulation and ground capacitance C_g represents insulation between turns to ground. Twelve mutual inductances have been used in analysis for winding represented by 8, 16 and 24 sections (Grover, 1962).

3. Simulation results

Figs. 2 and 3 show neutral current waveforms obtained without fault (I_{WO}) and with fault (I_{WF}) respectively for 16 sections representation of model winding for $\alpha = 10$. The resistance connected between neutral and ground is 5 Ω .

Fig. 4 shows difference in neutral current waveforms ($I_{WF} - I_{WO}$). The neutral current difference waveform clearly shows a region consisting of relatively low oscillations line shifted above zero because of fault in 8th section. The magnitude of current shift from zero to approximate average current line of low frequency oscillation is of the order 185 μ A. Similar results have been obtained for α values 10 and 20 for both 16 and 24 sections representation and fault in different section of winding. These results are tabulated in Table 1. We observe from Table 1 the neutral current difference magnitudes are predominantly in range of 100–200 μ A.

However, these results are found to be not valid for value of α equal to 5 and for 8 sections representation of same model winding even though the neutral current measurement resistance connected between neutral and ground was

Download English Version:

<https://daneshyari.com/en/article/556252>

Download Persian Version:

<https://daneshyari.com/article/556252>

[Daneshyari.com](https://daneshyari.com)