



# Incremental modeling of relaxation of prestressing wires under variable loading and temperature

Ponleu Chhun<sup>a</sup>, Alain Sellier<sup>a</sup>, Laurie Lacarriere<sup>a,\*</sup>, Sylvain Chataigner<sup>b</sup>, Laurent Gaillet<sup>b</sup>

<sup>a</sup> Université de Toulouse, UPS, INSA, LMDC (Laboratoire Matériaux et Durabilité des Constructions), 135 Avenue de Rangueil, 31077 Toulouse Cedex 04, France

<sup>b</sup> LUNAM University, IFSTTAR/SMC Route de Bouaye, 44344 CS4 Bouguenais cedex, France

## HIGHLIGHTS

- The coupling of non-linear effects of temperature and initial load ratio on relaxation is considered.
- The model for relaxation of prestressing bars at high-temperature (20–140 °C) is developed.
- The model is validated for relaxation test with a stepwise heating (20 °C–100 °C–140 °C).

## ARTICLE INFO

### Article history:

Received 17 May 2017

Received in revised form 12 December 2017

Accepted 15 December 2017

### Keywords:

Prestressing wire  
Relaxation  
Loading ratio  
Elevated temperature  
Incremental model

## ABSTRACT

This paper presents a model of prestressing steel relaxation under various levels of loading and temperature. This incremental model enables the delayed strain of prestressing steel wires to be calculated and takes the non-linear coupling of temperature and loading effects into account. It considers different experimental results that could occur in nuclear containment structures, for which a temperature up to 140 °C could be reached for prestressing wires should a loss-of-coolant accident occur. The constitutive law for prestressing steel relaxation is presented, followed by an illustration of the numerical implementation of the proposed model. Finally, the model responses are confronted with experimental results available in the literature supplied by Toumi Ajimi et al. (2017) for the thermo-mechanical conditions between 20 and 140 °C in terms of temperature and 70%–80% of loading ratio.

© 2017 Elsevier Ltd. All rights reserved.

## 1. Introduction

In the context of extending the life of nuclear containment structures, which form the third and last protection barrier of a nuclear reactor building, prestressing steel wires with high elastic limit and high tensile strength are required to improve the tensile strength of the whole concrete structure and to prevent possible leakage of radioactive elements in case of an accident with potential failure of the first two barriers. However, steel wires can undergo a loss of tension (relaxation) when they are subjected to an imposed strain, especially when they are simultaneously subjected to high temperature [1–5] as could be the case during an accident [6].

Predicting the stress relaxation of prestressing steel tendons is usually dealt with in the standard codes by using empirical laws

determined for a specific and constant initial load and temperature [7] (BPEL annex 2, article 3 & BPEL annex 6, article 4.1).

However, it is observed in the literature that loading stresses have a major influence on the mechanical properties of wires, including their relaxation behavior [8,9]. Erdelyi [10] obtained values of relaxation varying between 1.8% and 5.1% for loading ratios of 60% and 90% respectively on a prestressing central wire after 5000 h of test. The same relaxation behavior versus prestress ratio has been highlighted by Magura et al. [11]. Some models have thus been developed based on the code formulas to take account of the effect of initial prestress on relaxation [11,12] but they do not consider the effect of temperature, despite its strong influence on relaxation rate as shown by Rostasy et al. [13].

In the context of the present work, which is part of the French national research project MACENA (Control of Nuclear Vessel in Accident Conditions), which aims to study the behavior of a nuclear containment structure during a loss-of-coolant accident, where the rebars and tendons of the prestressed concrete containment structure may be subjected to temperatures up to 140 °C. The evaluation of the long-term reliability of these structures exposed

\* Corresponding author.

E-mail addresses: [chhun@insa-toulouse.fr](mailto:chhun@insa-toulouse.fr) (P. Chhun), [sellier@insa-toulouse.fr](mailto:sellier@insa-toulouse.fr) (A. Sellier), [laurie.lacarriere@insa-toulouse.fr](mailto:laurie.lacarriere@insa-toulouse.fr) (L. Lacarriere), [sylvain.chataigner@ifsttar.fr](mailto:sylvain.chataigner@ifsttar.fr) (S. Chataigner), [laurent.gaillet@ifsttar.fr](mailto:laurent.gaillet@ifsttar.fr) (L. Gaillet).

to such temperature increases thus requires a numerical model able to predict the relaxation of prestressing wires considering the impacts of variable temperature and initial loading (prestress). Moreover, as the influence of variation in temperature and loading ratio on the relaxation rate tends to be relatively complex, the necessity for an efficient incremental model to simulate the delayed strain of prestressing wires in different thermomechanical conditions is clear. Adapted from an incremental rheological model of delayed strain in concrete [14], the present model is proposed to take the non-linearity of thermomechanical couplings into account.

The originality of this article lies in a comparison between experimental data supplied by Toumi Ajimi et al. [15] and results predicted by the model. Two laboratories collaborated in this work: IFSTTAR/SMC and LMDC. The first part of the paper briefly recalls the experimental test conditions for relaxation of prestressing central wires at different temperatures. Further details can be found in the work of Toumi Ajimi et al. [15]. Then, in the second part, the constitutive equations of the proposed model are given, followed by a numerical implementation. In this part, the influence of temperature on relaxation rate is pointed out and the non-linear relation between loading ratio and relaxation rate is also modelled, in the same ways as the thermomechanical coupling. In the third part, various relaxation tests are simulated and the numerical predictions are compared to experimental results given in Ref. [15]. These tests concern stress relaxation at various loading ratios and temperatures, and stepwise cooling/heating in which prestressing steel wires are subjected to unloading/reloading during the temperature changes.

## 2. Experiments

An experimental program was designed on T15.2 prestressing wires at different temperature levels and under different loading ratios. The tests were performed on central steel wires at constant temperature, using a maximum value of 20 °C, 40 °C, 100 °C or 140 °C. Both tensile and stress relaxation tests were carried out by Toumi Ajimi et al. [15]. The results regarding the evolution of tensile behavior with temperature are given in Table 1.

In stress relaxation investigations, two levels of initial stress ratio (0.7 and 0.8) were studied for each temperature level. The experiments of Toumi Ajimi et al. [15] showed that the relaxation was more affected at higher temperature and higher stress ratio. In addition, at 20 °C, two other initial stress ratios were investigated: 0.6 and 0.9. More details can be found in Ref. [15].

It is important to note that, in both cases, the temperature state, although stationary, was not constant along the extensometer (Fig. 1). However, for each configuration, the average temperature was assessed using temperature sensors. For tensile tests, the average temperatures were 30 °C, 79 °C and 110 °C for ultimate temperatures of 40 °C, 100 °C and 140 °C, respectively. For stress relaxation investigations, they were assessed to be respectively 35 °C, 76 °C and 100 °C.

In addition, stepwise heating and cooling were performed on the same type of wires under a stress ratio of 0.8. The first transient test started at 20 °C, rising to 100 °C and finally 140 °C. Second one

**Table 1**  
Experimental mechanical properties of prestressing wires (tensile tests) [15].

Maximum temperature, °C	$f_y$ , MPa	$E$ , GPa
20	1867 ± 3	226.1 ± 5.0
40	1854 ± 15	226.3 ± 0.9
100	1793 ± 4	224.5 ± 3.4
140	1726 ± 14	213.4 ± 1.1

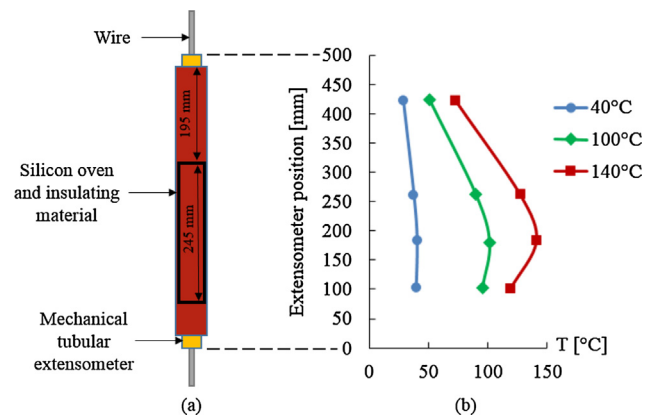

**Fig. 1.** Scheme of relaxation sample with the heating device on the prestressing wire (a) and temperature evolution along the heated section (b) [15].

started at 140 °C, followed by 100 °C and finally 20 °C. For these two tests, a specific loading/unloading procedure was adopted to exclude thermal expansion effects from the results. For each step, the wire was unloaded before its temperature state was modified, and was then loaded again with the remaining load obtained from the preceding step. Results are given in Figs. 5 and 6, where they are compared with the model predictions.

## 3. Constitutive equations

### 3.1. Model principles

The relaxation model is based on the rheological model summarized by an idealized scheme in Fig. 2. It consists of three levels, an elastic part to model instantaneous behavior, a Kelvin module to model viscoelastic strain, and a nonlinear Maxwell module to model permanent strain. This model is formulated to be usable in nonlinear finite element codes able to consider incremental evolution of thermomechanical conditions, so it does not use relaxation functions but stores the material state only through state variables acting on instantaneous characteristics of material. These state variables are the strain of each level presented in Fig. 2, the applied stress and the maximum loading rate. To consider the progressive reduction of the relaxation kinetics, the Maxwell level is nonlinear, its viscosity depending on the strain of the Maxwell level ( $\varepsilon^M$  in Fig. 2). A nonlinear Maxwell module has already been used successfully, and for the same reason, to model the decrease of concrete creep kinetics [14].

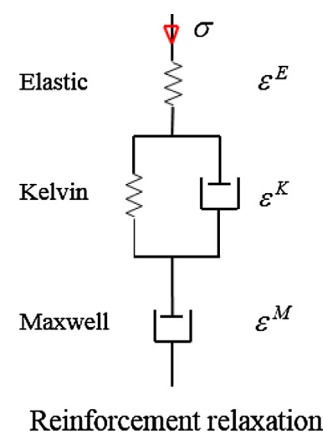

**Fig. 2.** Idealized rheological scheme for relaxation model.

Download English Version:

<https://daneshyari.com/en/article/6716232>

Download Persian Version:

<https://daneshyari.com/article/6716232>

[Daneshyari.com](https://daneshyari.com)