



Small wind power generation using automotive alternator



Samuel Ofordile Ani*, Henk Polinder, Jan Abraham Ferreira

Electrical Power Processing, Delft University of Technology, Mekelweg 4, 2628 CD Delft, The Netherlands

ARTICLE INFO

Article history:

Received 20 March 2013

Accepted 4 December 2013

Available online 25 December 2013

Keywords:

Automotive alternator

Battery charging

Energy yield

Generated energy cost

Small wind turbine

Speed transmission

ABSTRACT

The objective of this paper is to evaluate the feasibility of using claw pole automotive alternator as a generator for small wind turbine and to compare its energy yield and generated electricity cost with commercially available systems. The comparison is based on the energy yield per swept area and cost per energy produced in a low wind speed climate. Concepts such as the selection of suitable turbine parameters and gear ratio were used to achieve good matching of the turbine characteristics with measured alternator performance in order to improve the energy yield from the alternator in battery charging application. The energy yield from the alternator integrated to a 3.9 m diameter turbine is comparable with many commercially available turbines. The generated electricity cost of a commercially available turbine can be reduced by more than a factor of 2 by replacing its generator with our proposed alternator. The alternator-based turbine system is therefore a low cost solution aimed at making wind energy available to areas where the current cost of wind technology makes it prohibitive.

© 2013 Published by Elsevier Ltd.

1. Introduction

Wind energy accounts for an increasing percentage of the energy supplied to the electricity network. Electricity generation from wind is now cheaper than other renewables and almost cost competitive with other conventional sources of electricity generation. However, this impressive growth is largely due to advances in large wind turbines. Small wind turbines on the other hand have not been developing at such an impressive rate. In the past few years, an annual growth rate of about 30% has been recorded in the installed large wind power capacity while the average growth of small wind turbines was 9%. This is despite its huge potentials in providing electricity to more than 1 billion people living mostly in developing countries without electricity.

A major reason for the continued low penetration of small wind turbines is the high cost of current systems. A study of the energy yield of commercially available small wind turbines shows that the cost of generated electricity (and cost per rated power) of the most cost effective and the least cost effective small wind turbines are respectively €0.34/kWh (and €3200/kW) and €4/kWh (and €8500/kW), compared with €0.05/kWh (and €1300/kW) for large wind turbines [1]. This analysis is also supported by European Wind Energy Association [2] where it was reported that the cost of

current stand-alone small wind turbines varies from €2500 to €6000 per installed kW.

The generator is a key component of small wind turbines and is responsible for converting the mechanical energy from the turbine into electrical energy. Obviously, reducing the cost of generators used for small wind turbines will lower the overall cost of the turbine, thereby by making it cost competitive.

A study of the characteristics of commercially available small wind turbines in the range of 100 W–5000 W shows that most small wind turbines use direct-drive permanent magnet synchronous generators. However, the market for permanent magnets can sometimes be a subject of politics leading to a situation where the availability of PMs cannot be guaranteed at all times. Furthermore, the high cost of PMs increases the cost of the generator, and hence the turbine. Claw pole automotive alternators can provide low cost alternative to PM generators for small wind turbine application.

This choice is motivated by the following reasons.

- 1) Low cost: due to the high volume of alternators manufactured yearly for automotive application, they are inexpensive.
- 2) Availability: alternators can be found in most parts of the world.
- 3) Maintainability: in automotive application, alternators have been found to have high robustness even when they are used in harsh operating conditions.
- 4) They are designed specifically to generate electricity for battery charging.

* Corresponding author.

E-mail addresses: s.o.ani@tudelft.nl, samofordile@yahoo.com (S.O. Ani).

5) Availability of skills: even in remote rural areas, skills for this technology are available albeit for automotive application. Using this as a starting point it would be possible to utilize existing skills and make the required transition to wind turbine application.

The objective of this paper is to evaluate the feasibility of using claw pole automotive alternator as a generator for small wind turbine and to compare its energy yield and generated electricity cost with commercially available systems. The alternator output performance is determined via measurement tests. In order to improve the energy yield from the alternator integrated to a turbine in battery charging application, the measured output from the alternator has to match the turbine output characteristics. Concepts to achieve good matching of the turbine characteristics with alternator are presented. The energy yield and generated energy cost from the alternator integrated to a specific turbine are presented and compared with values for commercially available systems. The comparison is based on the energy yield per swept area and cost per energy produced in a low wind speed climate. A low wind speed site is used because small wind turbines operate mostly in low wind sites, being sited where the energy is needed and not necessarily where the wind is best. This comparison and the proposed concepts to optimize the alternator performance in order to achieve good matching of the turbine characteristics with alternator are the original contributions of this paper.

The paper starts with the development of models to describe alternator performance which are then validated via measurement tests. Concepts to optimize the alternator and achieve good matching of the turbine characteristics with alternator are presented next. The paper concludes with a comparison of the energy yield and energy cost from the alternator integrated to a specific turbine with that of commercially available systems.

2. Modelling of alternator performance

The main parts of a typical claw pole alternator are shown in Fig. 1. The stator core is uniformly laminated with windings placed in slots. The stator has three-phase star or delta connected AC windings, typically single layer with number of slots per pole per phase ($q = 1$). The windings are machine-inserted in the slots, with a modest slot fill factor of about 0.3–0.32 [3]. The rotor consists of claws made of solid iron that surround a ring shaped DC-excitation field windings. Power is transferred to the DC excitation field windings on the rotor via copper slip-rings and carbon brushes. Bearing and rotor shaft on opposite side (drive end side) complete the rotor assembly. In automotive application, the generator is driven by the internal combustion engine through a belt transmission.

The AC generated by the alternator is rectified via an inbuilt three phase diode bridge rectifier and connected to the battery. A 14 V DC system is currently being used, but the 42 V DC system is being proposed as the new standard for automotive applications due to increasing load demand in today's vehicles [3,4]. The output

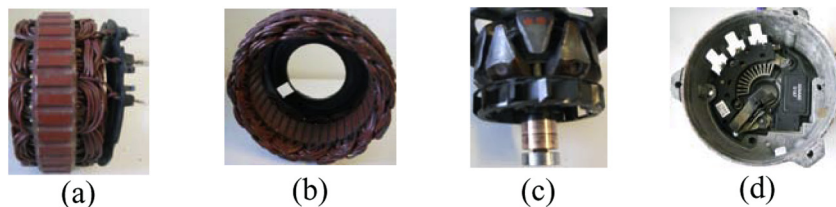

Fig. 1. Components of a typical automotive alternator: a) and b) stator showing the teeth and slots; c) rotor; and d) power electronics. The stator has laminated core with copper wires inserted in slots. The field windings in the rotor are made of fine wire and enclose the rotor claws made of solid iron. The power electronics consists of diode rectifier and inbuilt regulator.

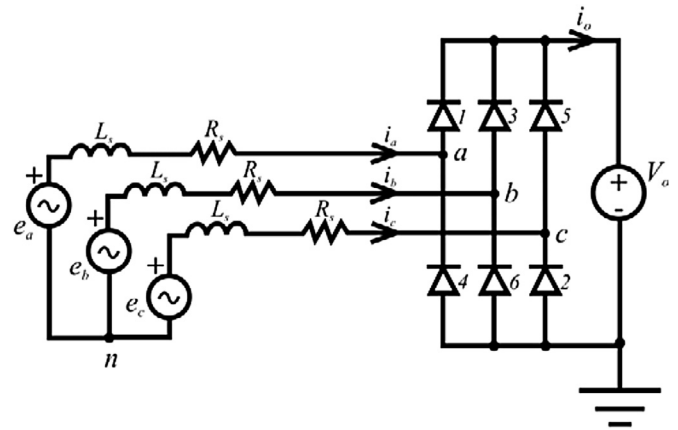

Fig. 2. Three-phase diode bridge rectifier with a constant voltage load and ac-side inductance and resistance.

voltage is normally maintained at 14 V DC (for 14 V battery system) by an internal regulator that samples the battery voltage and adjusts the field current accordingly. The regulator maintains the desired voltage by varying the duty-cycle of the pulse width modulated (PWM) voltage applied to the field winding. As the electrical load in the vehicle increases, more current is drawn from the alternator and the output voltage decreases. The regulator detects this drop in voltage and increases the voltage by increasing the duty cycle to increase the field current, and vice versa when there is a decrease in electrical load.

The alternator system can be modelled as a three-phase AC synchronous generator supplying a constant voltage load for battery charging via a three-phase diode bridge rectifier as shown in Fig. 2. The system comprises a three-phase voltage source with series inductance and resistance representing the synchronous generator back EMF, inductance and resistance, while the constant voltage load represents the battery and connected system loads.

In this paper it is assumed that the inductance L_s is large enough to ensure continuous ac-side conduction. Continuous conduction mode (CCM) is defined with respect to the ac line currents to mean that the ac line currents i_a , i_b , and i_c vary continuously and do not remain at zero for some part of the cycle [5].

As shown in Fig. 2 the voltage source of the diode bridge rectifier is supplied from a star-connected three-phase set of sinusoidal voltages e_a , e_b , and e_c with angular frequency ω :

$$e_a = \sqrt{2}E_s \sin(\omega t) \quad (1)$$

$$e_b = \sqrt{2}E_s \sin(\omega t - 2\pi/3) \quad (2)$$

$$e_c = \sqrt{2}E_s \sin(\omega t + 2\pi/3) \quad (3)$$

where the amplitude of the voltages is given by $E_m = \sqrt{2}E_s$.

Download English Version:

<https://daneshyari.com/en/article/6768491>

Download Persian Version:

<https://daneshyari.com/article/6768491>

[Daneshyari.com](https://daneshyari.com)