

Solar still with vapor adsorption basin: Performance analysis



R. Kannan^a, C. Selvaganesan^b, M. Vignesh^b, B. Ramesh Babu^b, M. Fuentes^c, M. Vivar^d,
I. Skryabin^d, K. Srithar^{b,*}

^a Roever Engineering College, Perambalur, Tamilnadu 621212, India

^b Thiagarajar College of Engineering, Madurai, Tamilnadu 625015, India

^c Grupo IDEA, Universidad de Jaen, Jaen 23071, Spain

^d Centre for Sustainable Energy Systems, Australian National University, Canberra 0200, Australia

ARTICLE INFO

Article history:

Received 14 December 2012

Accepted 8 July 2013

Available online

Keywords:

Solar still

Vapor adsorption

Desalination

Efficiency

Water purification

ABSTRACT

In this work, a vapor adsorption type solar still was designed, fabricated and tested at Thiagarajar College of Engineering, Madurai, India. A vapor adsorbent pipe network comprising activated carbon–methanol pair was integrated with the basin. Losses from the bottom of the still are considerably reduced due to sensible heat absorption by the activated carbon and latent heat of vaporization by methanol. Also water circulated through the inner tube of the adsorbent bed is used as a feed to basin, thus enhancing the evaporation rate during day time. The increase in temperature of the basin due to adsorbent bed and condensation of methanol vapor, augments the evaporation rate during the night time also. Sponges, gravels, sand and black rubbers were used in the vapor adsorption type solar still for improving the yield. Experimental results were compared with ordinary conventional basin type still. The governing energy balance equations for both conventional and vapor adsorption type solar still were solved analytically and compared with experimental results. Theoretical analysis gave very good agreement with experimental results.

© 2013 Elsevier Ltd. All rights reserved.

1. Introduction

As population of this planet has rapidly grown, we have increasingly tapped deeper into our planets fresh water resources. The trend of population growth is quite obvious. The availability of water in sufficient quantities and quality is a challenge of significant importance in many regions as it is scarce and unevenly distributed resource. Water scarcity is a function of supply and demand and an indicator of the gap between them.

The increased demand associated with uncontrolled development, inadequate management practices, overpopulation, mass tourism, intensive agriculture, and over consumption results in a complexity of interrelated problems affecting social, economic and natural aspects of everyday life. As a result many regions are now in a perpetual state of demand consistently exceeding supply.

Solar distillation extracts potable water from a salty or polluted source using a simple process which is particularly well-suited for use on small scale in remote or developing regions. Solar stills of

diverse designs, many equipped with numerous improvements, have been widely studied and put into use.

Tiwari et al. [1] reviewed the present status of solar distillation. The basic heat and mass transfer relation responsible for developing, testing procedure for various designs of solar stills have also been discussed.

Tanaka and Nakatake [2] have proposed a novel compact multiple-effect diffusion-type solar still consisting of a heat-pipe solar collector and a number of vertical parallel partitions in contact with saline-soaked wicks to increase the evaporation rate.

Abu-Hijleh and Rababa'h [3] have done the experimental study of a solar still with sponge cubes in basin. The effects of sponge cube size, volume ratio of sponge, water depth, water salinity and the use of black coal and black steel cubes were also investigated. The study showed that the daily output of such a still could be greatly enhanced using sponge cubes.

Badran et al. [4] designed a solar still augmented with flat plate collector. The still inlet was connected to a locally made fin-tube collector such that its outlet was fed to the still basin instead of the common storage tank. Velmurugan and Srithar [5] integrated a mini solar pond for enhancing the productivity of solar still. Also they reviewed [6] various applications of solar pond. Fins [7,8], stepped solar still [9] were also used to enhance the productivity of

* Corresponding author. Tel.: +91 984 2185302; fax: +91 452 2483427.
E-mail address: ponsathya@hotmail.com (K. Srithar).

the solar still. Also an extensive review on solar desalination system has been carried out by Velmurugan and Srithar [10].

Leite and Dagueuet [11] have proposed a predictive model for an adsorption solar cooling system using the activated carbon and methanol pair and found its numerical simulation. Wang et al. [12] have done a research of a combined adsorption heating and cooling system. The experiments showed the potentials of the application of the solar powered hybrid water heater and refrigerator. Dai and Sumathy [13] investigated the heat and mass transfer in the adsorbent of a solar adsorption cooling system. A mathematical model, which accounts for the heat and mass transfer of sorption (adsorption and desorption) processes as well as the effects of non-equilibrium and non-uniform temperature and pressure distribution, was developed and experimentally validated.

Liu et al. [14] proposed a new adsorption refrigeration system, without refrigerant valves, and solved the problem of mass transfer resistance resulting in pressure drop along refrigerant passage in conventional systems when methanol or water is used as a refrigerant. Anyanwu and Ogueke [15] proposed the thermodynamic design procedure for solid adsorption solar refrigeration using activated carbon/methanol, activated carbon/ammonia and zeolite/water adsorbent/adsorbate pairs. Sumathy and Zhongfu [16] described the operation of a solar-powered ice-maker with the solid adsorption pair comprising activated carbon and methanol.

The literature survey showed that higher water temperatures resulting in the increase in evaporation rate are achieved by decreasing the saline water depth in the basin, by increasing the exposure area or by preheating the saline water by some other sources before it enters the still or by combining all. The vapor adsorption solar refrigeration techniques using activated carbon–methanol or activated carbon–ammonia pairs gave good result in solar cooling process because of the higher sensible heat of activated carbon and the latent heat of methanol/ammonia.

The objective of this work is to increase the temperature of saline water by utilizing an adsorbent bed pipe network with activated carbon–methanol pair embedded in the basin of the solar still. In an inner tube of the adsorbent pipe network, saline water is

circulated from the storage tank. This preheated water is used as a feed to the still. An outer pipe of the adsorbent pipe network is enclosed with activate carbon–methanol pair and sealed at both ends. The temperature of the saline water is further augmented by means of adding the sensible heat storage materials like sponge, sand and rubber on the basin. Also adding sponges in the basin will increase the exposure area to solar radiation and thus evaporation rate is increased. Results showed that there is good improvement in distillate production in both day and night times. Theoretical modeling is also carried out to validate the experimental results.

1.1. Experimentation

The vapor adsorption type solar still system comprises vapor adsorbent bed is shown in Figs. 1 and 2. The solar still consists of a 25 mm thick plywood box with dimensions depicted in Figs. 1 and 2. Holes are provided for the distilled water output and for the brackish water input. Outer sides of the wooden box are covered by the metal sheet in order to protect the box from solar radiation and rain. The basin of the still is made up of 2 mm galvanized iron (GI) sheet selected due to its good conductivity and low cost. The dimensions of the basin are $1 \times 1 \text{ m}^2$. A 0.2 m gap between the side of the basin tray and the wooden box is filled with saw dust. This acts as insulation and prevents the side loss of heat through conduction. The basin is coated with black paint to increase the radiation absorption.

The condensing surface in the still is simply a $1.1 \times 1.1 \text{ m}^2$ sloping glass cover. Distilled water condensed on the glass surface is collected by a piece of gutter attached at the bottom of the sloping cover and directed to a measuring jar. The slope was selected as 10° angle, which is the latitude of Madurai, Tamil Nadu, India. The still is positioned that the glass cover faced south direction during all experiments.

The only modification made in the basin plate of the vapor adsorption type solar still is the integration of a concentric pipe line network in the basin as shown in Figs. 1 and 2. An inner pipe of this network is 0.025 m in diameter and is enclosed with an outer pipe

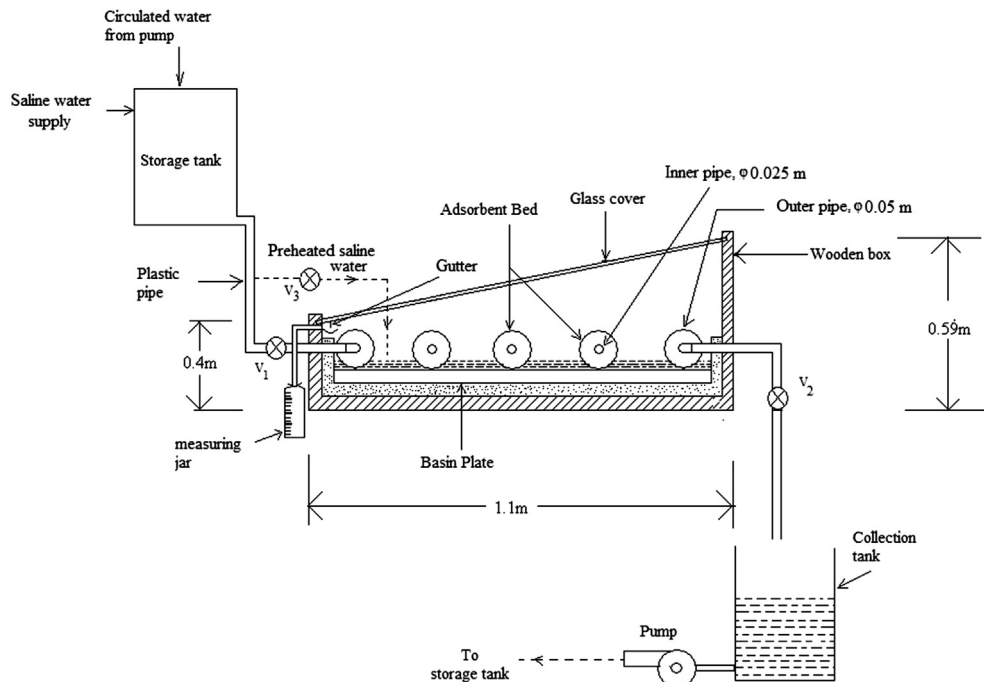

Fig. 1. Schematic diagram of the vapor adsorption type solar still.

Download English Version:

<https://daneshyari.com/en/article/6768839>

Download Persian Version:

<https://daneshyari.com/article/6768839>

[Daneshyari.com](https://daneshyari.com)