



ELSEVIER

Contents lists available at ScienceDirect

Mechanical Systems and Signal Processing

journal homepage: www.elsevier.com/locate/ymssp

Shifting and power sharing control of a novel dual input clutchless transmission for electric vehicles

Jiejunyi Liang, Haitao Yang, Jinglai Wu*, Nong Zhang, Paul D. Walker

Faculty of Engineering and IT, University of Technology, Sydney, 15 Broadway, Ultimo 2007, NSW, Australia



ARTICLE INFO

Article history:

Received 10 August 2017

Received in revised form 15 November 2017

Accepted 20 November 2017

Available online 29 November 2017

Keywords:

Dual input clutchless transmission

Torque hole compensation

Shifting control

Power sharing control

Drivability

ABSTRACT

To improve the overall efficiency of electric vehicles and guarantee the driving comfort and vehicle drivability under the concept of simplifying mechanism complexity and minimizing manufacturing cost, this paper proposes a novel clutchless power-shifting transmission system with shifting control strategy and power sharing control strategy. The proposed shifting strategy takes advantage of the transmission architecture to achieve power-on shifting, which greatly improves the driving comfort compared with conventional automated manual transmission, with a bump function based shifting control method. To maximize the overall efficiency, a real-time power sharing control strategy is designed to solve the power distribution problem between the two motors. Detailed mathematical model is built to verify the effectiveness of the proposed methods. The results demonstrate the proposed strategies considerably improve the overall efficiency while achieve non-interrupted power-on shifting and maintain the vehicle jerk during shifting under an acceptable threshold.

© 2017 Elsevier Ltd. All rights reserved.

1. Introduction

Transportation systems are experiencing considerable changes in terms of electrification because of the mounting demand for reduction of fossil fuel consumption and green-gas emissions and the improvements of vehicle overall efficiency. In the past decades, groundbreaking achievements have been made in the realms of researches and industries to build more intelligent and more eco-friendly new energy vehicles, such as electric vehicles [1], hybrid electric vehicles [2] and fuel cell electric vehicles [3]. All of these approaches have to some certain extent helped alleviate the aforesaid problems, but there are still challenges to further improve the energy consumption performance while maintaining satisfactory vehicle drivability as drivability generally goes against the optimization of energy consumption [4].

In order to achieve a desirable balance between efficiency and drivability, two aspects can be focused on which are powertrain architecture [5] including advanced vehicle dynamic control, and energy management strategies (EMS) [6]. Many successful commercial pure electric vehicles, which could achieve good acceleration performance and relatively low energy consumption, have been promoted to customers such as Nissan Leaf, Mitsubishi iMIEV and Tesla. For most on sale pure electric vehicles, single fixed ratio transmission system serve as a core component of their powertrains, the merits of this kind of architecture are lower manufacturing cost, relatively smaller volumes and less drive train mass [7]. Besides the advantages, the drawbacks of this kind of transmission system are also obvious which are compromised drivability performance comes

* Corresponding author.

E-mail address: jinglai.wu@uts.edu.au (J. Wu).

from compromises between speed and torque range and lower overall efficiency because of the non-adjustable transmission ratios.

Multi-speed transmission system is an effective solution to further improve the overall efficiency and guarantee the drivability for electric vehicles [8]. However, most existing investigations of multi-speed transmission systems are focused on ICE-related vehicles such as conventional ICE vehicles and HEV. As a result, conventional multi-speed transmission architectures and the related control strategies cannot be directly adopted in pure electric vehicles. Moreover, the differences between electric motor and ICE give electric vehicles more advantages to make the most of these transmission systems. As maximizing the overall efficiency is one of the priorities in designing electric vehicle transmission, automated manual transmission (AMT) stands out as it provides the highest efficiency, meanwhile, has low manufacture cost and is light in weight, among all alternative options [9]. But its popularization is hindered due to two drawbacks which are jerks caused by torque interruption in shifting process and excessive wear of friction components. Extensive studies [10] have proved that the major parasitic losses in transmission system come from friction clutch elements and electro-hydraulic actuators and these two account for 4–6% losses of overall efficiency. In [11], it is proved possible to minimize the reduction in efficiency by using clutchless variants.

To solve the torque interruption problem, many feasible solutions have been proposed such as adding a servo-assisted clutch to replace the fifth synchronizer in [12], the additional clutch could provide certain power when the ICE is disconnected from the transmission during gear shifting. This method could only alleviate the torque hole problem as it doesn't have its own power source. In [13], a modification is made to the original AMT which puts the gearbox before the friction clutch and to some extent, solves the problem of torque interruption. As to the problem of excessive wear of friction components and parasitic losses, the adoption of electric motors provides a desirable solution which is to avoid using friction clutches. For conventional ICE vehicles, the adoption of friction clutches is inevitable as the inertia of the engine is too high to perform prompt speed and torque adjustment, and it also entails long speed synchronization duration and exacerbates the wear of the friction plates. Due to three advantages of electric motors [14] which are small inertia, excellent low speed control capabilities and torque/speed operation modes, a clutchless AMT could be designed for electric vehicles. Aiming at maximizing overall efficiency and solving the aforesaid problems, Fig. 1 shows the proposed transmission architecture.

To achieve a non-interruption power-on shifting, suitable shifting control strategy should be designed and implemented [15]. Through precisely control the torque and speed profiles of the first motor and the second motor, the final shaft torque would stay steady during gear shifting with which a smooth and power-on shifting process could be achieved. The detailed shifting control strategy is discussed in Section 3.

Solving the problem of architecture design and its shifting control strategy alone can only partly guarantee the efficiency and drivability, the performance of the proposed dual input clutchless transmission system also depends on how to distribute the power demand among the two motors [16]. Only by controlling the two motors work in their higher efficiency region can the system provide satisfying dynamic and efficient performance [17].

Many profound researches have been conducted in the field of energy management which roughly divide the methods into two categories: rule-based control and optimization based control [18]. Rule-based control is famous for its simplicity which comes from the avoidance of explicit optimization algorithm [19]. Compared with optimization-based approaches, rule-based methods are more effective in real-time implementation because the time-consuming calibration and tuning work for various parameters are conducted off-line before implementation. The fundamentals of the rules are usually heuristic, intuitive, and experiential [20] which make them generate suboptimal results under different driving conditions. According to the way the rules are designed, rule-based control can be further divided into deterministic rule-based and

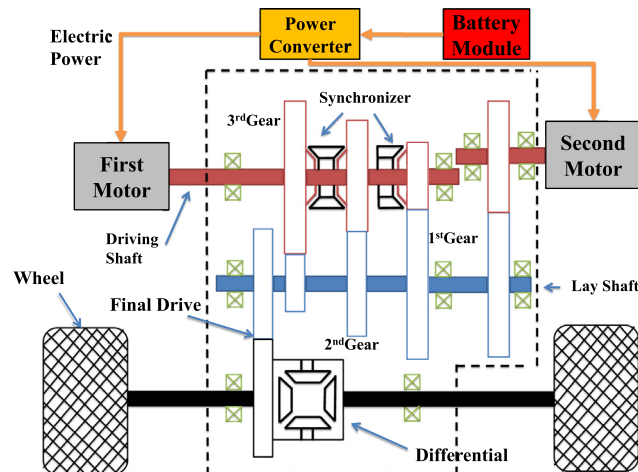

Fig. 1. Proposed dual input clutchless transmission system.

Download English Version:

<https://daneshyari.com/en/article/6954683>

Download Persian Version:

<https://daneshyari.com/article/6954683>

[Daneshyari.com](https://daneshyari.com)