



Full length article

# Optical millimeter-wave generation with tunable multiplication factors and reduced power fluctuation by using cascaded modulators

Hongyao Chen, Tigang Ning, Jing Li, Li Pei\*, Jin Yuan, Jingjing Zheng, Ling Liu

Key Lab of All Optical Network &amp; Advanced Telecommunication Network of EMC, Institute of Lightwave Technology, Beijing Jiaotong University, Beijing 100044, China



## ARTICLE INFO

## Article history:

Received 21 December 2016  
 Received in revised form 18 October 2017  
 Accepted 5 January 2018

## Keywords:

Fiber optics and optical communications  
 Microwave photonics  
 Millimeter-wave generation  
 Optical sideband suppression ratio  
 Reduced power fluctuation

## ABSTRACT

In this study, we propose and demonstrate a prototype for optically generating millimeter-wave (MMW) signals with tunable multiplication factors and reduced power fluctuation. The proposed scheme is based on two Mach-Zehnder modulators (MZM) and a polarization control system. By controlling the polarization direction, the amplitudes of first and third order optical sidebands can be flexibly controlled. The optical sideband suppression ratio (OSSR) between them can be tuned within the range of 50 dB to –50 dB, which provides an opportunity to convert the multiplication factor between 2 and 6. Benefited from the high OSSR, the generated MMW signals show anti-power fluctuation capability either in the transmission process or in the frequency-tuning process. The relations of received signal power, transmission distance, bit error rate (BER), receiver sensitivity, power penalty and a contrast experiment are discussed in this paper.

© 2018 Elsevier Ltd. All rights reserved.

## 1. Introduction

Fiber optical transmission operating at millimeter-wave (MMW) frequency, as a key technology for future high-capacity communication and all-optical network has attracted much attention. For utilizing the MMW resource to provide broader bandwidth, the radio over fiber (RoF) technology is currently considered as an effective way, where radio signals in optical carrier state at central station (CS) are delivered to base stations (BSs) through an optical network, and then photoelectric conversion at BSs [1–3]. In order to obtain a high-quality MMW carrier, various techniques have been developed, such as the optical phase-locked loop [4], the use of nonlinear effect in optical fiber [5,6] and the optical frequency up-conversion using an external modulator [7–10]. Among these methods, the external modulation with optical frequency up-conversion has been regarded as a promising method due to its simple, cost-effective implementation and low phase noise. However, the external modulator usually generates an optical double-sideband (DSB) or optical carrier suppression (OCS) signal with fixed multiplication factor and some harmonic sidebands. Thus, the fiber chromatic dispersion causes signal power fluctuation along the fiber length [11]. Although, there are some techniques to compensate the chromatic dispersion, but too many adaptable dispersion compensators will increase the

complexity of system. Eliminating harmonic sidebands seems to be a good choice; they are easy to be suppressed by using an optical fiber grating or an optical filter [12,13], while the frequency tunability of the system is limited by the fixed bandwidth of optical filter.

In this paper, we propose a prototype for high-quality MMW carriers generation based on cascaded modulators and a polarization control system. By controlling the polarization direction, the OSSR of the generated optical carriers can be flexibly controlled. Benefited from the tunable OSSR, the multiplication factor of the proposed system can be adjusted. Moreover, by adjusting the OSSR, the harmonic sidebands of the generated optical carriers can be suppressed effectively, which helps us to reduce the signal power fluctuation caused by the fiber chromatic dispersion. Compared with optical filter based technologies, the proposed scheme possesses tunable multiplication factor, good frequency tunability and reduced signal power fluctuation.

## 2. Structure and principle

The proposed optical MMW generator is shown in Fig. 1. The input optical field generated by a continuous wave (CW) laser is assumed as,

$$E_{in}(t) = E_0 \exp(j2\pi f_0 t). \quad (1)$$

where  $f_0$  denote the center frequency of CW laser and  $E_0$  represents the amplitude of optical field. The electrical driving signal assumed

\* Corresponding author.

E-mail address: [lipei@bjtu.edu.cn](mailto:lipei@bjtu.edu.cn) (L. Pei).

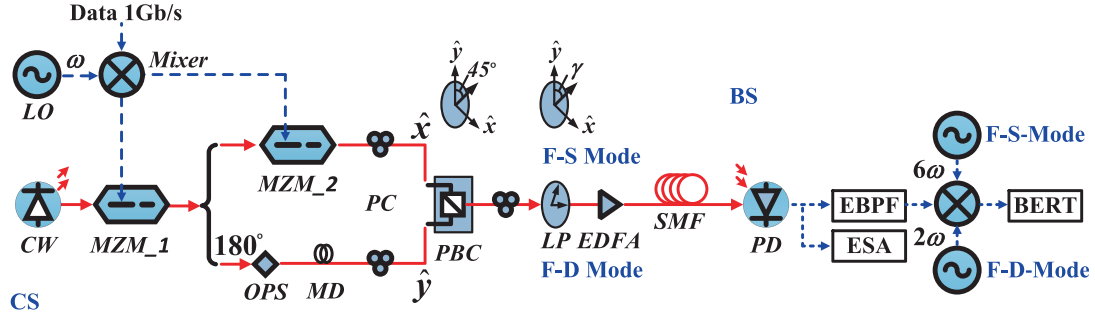

**Fig. 1.** Schematic diagram of the proposed optical MMW generator based RoF system. CS, center station (CW, continuous wave laser; LO, local oscillator; MZM, Mach-Zehnder modulator; OPS, optical phase shifter; MD, Matching delay; PC, polarization controller; PBC, polarization beam combiner; LP, linear polarizer; EDFA, Erbium-doped fiber amplifier); SMF, Single mode optical fiber; BS: base station (PD, photodiode; ESA, electrical spectrum analyzer; EBPF, electrical band-pass filter; BERT, bit error rate tester); F-D mode, frequency-doubling mode; F-S mode, frequency-sextupling mode.

as  $V_m \cos(2\pi f_m t)$  generated by a local oscillator (LO) is divided into two paths to drive two Mach-Zehnder modulators, MZM<sub>1</sub> and MZM<sub>2</sub>. The commercially available MZM<sub>1</sub> is biased at the minimum transmission point, thus the output optical field of MZM<sub>1</sub> can be expressed as

$$E_{MZM_1}(t) = E_0 \sum_{n=1}^{\infty} (-1)^n J_{2n-1}(m) \left\{ \begin{array}{l} \exp[j2\pi(f_0 - (2n-1)f_m)t] \\ + \exp[j2\pi(f_0 + (2n-1)f_m)t] \end{array} \right\}. \quad (2)$$

where  $J_n$  denotes the Bessel function of the first kind of order  $n$ .  $m$  is the phase modulation index of MZM<sub>1</sub>. When  $m$  equals to 0.9, the corresponding values of  $J_1(m)$ ,  $J_3(m)$ ,  $J_5(m)$  and  $J_7(m)$  are 0.4059,  $0.0144$ ,  $1.486 \times 10^{-4}$  and  $7.228 \times 10^{-7}$ , respectively. Thus, the optical sidebands higher than  $\pm 3$ rd order can be neglected without significant errors, and the output optical field of the MZM<sub>1</sub> can be simplified to

$$E_{MZM_1}(t) = -E_0 \left\{ \begin{array}{l} J_1(m) \exp[j2\pi(f_0 - f_m)t] \\ + J_1(m) \exp[j2\pi(f_0 + f_m)t] \\ - J_3(m) \exp[j2\pi(f_0 - 3f_m)t] \\ - J_3(m) \exp[j2\pi(f_0 + 3f_m)t] \end{array} \right\}. \quad (3)$$

After being modulated by the MZM<sub>1</sub>, the optical field will be divided into two parts; one is modulated by a commercially available MZM<sub>2</sub>, the other one is rotated by 180 degree via an optical phase shifter (OPS). Since  $J_3(m)$  is much smaller than  $J_1(m)$ , we can consider that only two frequency components  $f_0 - f_m$  and  $f_0 + f_m$  are affected by MZM<sub>2</sub>. When MZM<sub>2</sub> is biased at the maximum transmission point, the output optical field of MZM<sub>2</sub> can be written as

$$E_{MZM_2}(t) = \frac{1}{\sqrt{2}} J_3(m) \exp[j2\pi(f_0 - 3f_m)t] + \frac{1}{\sqrt{2}} J_3(m) \exp[j2\pi(f_0 + 3f_m)t] - \frac{1}{\sqrt{2}} E_0 J_1(m) J_0(\beta) \exp[j2\pi(f_0 - f_m)t] - \frac{1}{\sqrt{2}} E_0 J_1(m) J_0(\beta) \exp[j2\pi(f_0 + f_m)t] - \frac{1}{\sqrt{2}} E_0 \sum_{n=1}^{\infty} (-1)^n J_1(m) J_{2n}(\beta) \left\{ \begin{array}{l} \exp[j2\pi(f_0 - (2n+1)f_m)t] \\ + \exp[j2\pi(f_0 + (2n-1)f_m)t] \end{array} \right\} - \frac{1}{\sqrt{2}} E_0 \sum_{n=1}^{\infty} (-1)^n J_1(m) J_{2n}(\beta) \left\{ \begin{array}{l} \exp[j2\pi(f_0 - (2n-1)f_m)t] \\ + \exp[j2\pi(f_0 + (2n+1)f_m)t] \end{array} \right\}. \quad (4)$$

where  $\beta$  is the phase modulation index of MZM<sub>2</sub>. When  $\beta$  equals to 0.59, the corresponding values of  $J_0(\beta)$ ,  $J_2(\beta)$ ,  $J_4(\beta)$  and  $J_6(\beta)$  are

0.9149, 0.0423,  $3.101 \times 10^{-4}$  and  $9.041 \times 10^{-7}$ . Thus, the optical sidebands higher than  $\pm 2$ nd order can be neglected without significant error, and the output optical field of the MZM<sub>2</sub> can be simplified to

$$E_{MZM_2}(t) = \frac{1}{\sqrt{2}} E_0 [J_3(m) + J_1(m) J_2(\beta)] \cdot \exp[j2\pi(f_0 - 3f_m)t] + \frac{1}{\sqrt{2}} E_0 [J_3(m) + J_1(m) J_2(\beta)] \cdot \exp[j2\pi(f_0 + 3f_m)t] - \frac{1}{\sqrt{2}} E_0 [J_1(m) J_0(\beta) - J_1(m) J_2(\beta)] \cdot \exp[j2\pi(f_0 - f_m)t] - \frac{1}{\sqrt{2}} E_0 [J_1(m) J_0(\beta) - J_1(m) J_2(\beta)] \cdot \exp[j2\pi(f_0 + f_m)t] \quad (5)$$

Then, after the OPS, a matching delay (MD) is used to balance the two optical paths. Here, for convenience of calculations, the time delay factor is not introduced to the formula. The output optical field of MD can be written as,

$$E_{OPS}(t) = \frac{1}{\sqrt{2}} E_0 \left\{ \begin{array}{l} J_1(m) \exp[j2\pi(f_0 - f_m)t] \\ + J_1(m) \exp[j2\pi(f_0 + f_m)t] \\ - J_3(m) \exp[j2\pi(f_0 - 3f_m)t] \\ - J_3(m) \exp[j2\pi(f_0 + 3f_m)t] \end{array} \right\}. \quad (6)$$

By adjusting two polarization controllers (PC), the output optical fields of MZM<sub>2</sub> and MD are adjusted with orthogonal polarization. Making sure that the polarization direction of optical field generated by MZM<sub>2</sub> is overlapped to the principle axes  $x$  of polarization beam combiner (PBC), leaving an optical field generated by MD with its polarized direction along  $y$ , then the output optical field of PBC is,

$$\left\{ \begin{array}{l} E_x \propto \left\{ \begin{array}{l} -\frac{1}{\sqrt{2}} A_1 \{ \exp[j2\pi(f_0 - f_m)t] + \exp[j2\pi(f_0 + f_m)t] \} \\ + \frac{1}{\sqrt{2}} A_2 \{ \exp[j2\pi(f_0 - 3f_m)t] + \exp[j2\pi(f_0 + 3f_m)t] \} \end{array} \right\} \\ E_y \propto \left\{ \begin{array}{l} + \frac{1}{\sqrt{2}} A_3 \{ \exp[j2\pi(f_0 - f_m)t] + \exp[j2\pi(f_0 + f_m)t] \} \\ - \frac{1}{\sqrt{2}} A_4 \{ \exp[j2\pi(f_0 - 3f_m)t] + \exp[j2\pi(f_0 + 3f_m)t] \} \end{array} \right\} \end{array} \right\}. \quad (7)$$

In Eq. (7),  $A_n$  stands for

$$A_n = \begin{cases} E_0 J_1(m) J_0(\beta) - E_0 J_1(m) J_2(\beta), & n = 1 \\ E_0 J_3(m) + E_0 J_1(m) J_2(\beta), & n = 2 \\ E_0 J_1(m), & n = 3 \\ E_0 J_3(m), & n = 4 \end{cases} \quad (8)$$

Finally, a linear polarizer (LP) with its principle polarization direction  $\gamma$  ( $\gamma \neq 0^\circ$  or  $90^\circ$ ) related to  $y$  is employed. The optical field would be,

Download English Version:

<https://daneshyari.com/en/article/7128982>

Download Persian Version:

<https://daneshyari.com/article/7128982>

[Daneshyari.com](https://daneshyari.com)