



Contents lists available at ScienceDirect

## Journal of Quantitative Spectroscopy &amp; Radiative Transfer

journal homepage: [www.elsevier.com/locate/jqsrt](http://www.elsevier.com/locate/jqsrt)Extended sub-Doppler resolution spectroscopy of the  $\nu_3$  band of methanePhilip A. Kocheril<sup>a</sup>, Charles R. Markus<sup>a</sup>, Anne Marie Esposito<sup>a</sup>, Alex W. Schrader<sup>a</sup>, Thomas S. Dieter<sup>b,1</sup>, Benjamin J. McCall<sup>a,b,c,\*</sup><sup>a</sup> Department of Chemistry, University of Illinois at Urbana-Champaign, Urbana, IL 61801, USA<sup>b</sup> Department of Physics, University of Illinois at Urbana-Champaign, Urbana, IL 61801, USA<sup>c</sup> Department of Astronomy, University of Illinois at Urbana-Champaign, Urbana, IL 61801, USA

## ARTICLE INFO

## Article history:

Received 5 April 2018

Revised 29 April 2018

Accepted 30 April 2018

Available online 30 April 2018

## Keywords:

Methane

Mid-infrared

Sub-Doppler

## ABSTRACT

We have performed sub-Doppler resolution rovibrational spectroscopy of the  $\nu_3$  band of methane ( $^{12}\text{CH}_4$ ) in the mid-infrared using an optical parametric oscillator in a double-pass configuration for saturated absorption. An optical frequency comb was used for absolute frequency calibration. We have measured 22 methane line centers ranging from the  $P(13)$  to  $R(10)$  transitions with a typical uncertainty of 0.40 MHz. These measurements improve previously known transition frequencies by at least an order of magnitude.

© 2018 Elsevier Ltd. All rights reserved.

## 1. Introduction

Methane is a historically important molecule of study for scientists in many fields. Methane provided a fundamental guidepost for understanding molecular geometry and chemical bonding [1]. As the simplest stable hydrocarbon, methane has been and continues to be a key benchmark for molecular modeling and state-of-the-art *ab initio* calculations of potential energy and dipole moment surfaces [2,3]. Modern *ab initio* work is useful for predicting line strengths and supplementing incomplete experimental spectra, which can contribute to spectroscopic line lists like the HITRAN database [4]. Similarly, methane is relevant to the ExoMol project, which is focused on creating accurate astrophysical models of cool stars and extrasolar planets [5], since methane is a key constituent of planetary atmospheres [6,7] and brown dwarf atmospheres [8]. Here on Earth, methane is the third most abundant greenhouse gas and therefore a significant contributor to climate change [9], as well as being relevant to ozone depletion and formation [10].

Methane's rovibrational structure is best studied by mid-infrared spectroscopy due to its strong rovibrational transition dipole moments. However, its tetrahedral symmetry and overlap of normal mode frequencies for its four vibrational bands result in a highly complex vibrational structure. Specifically, the  $\nu_1$  and  $\nu_3$

bands consisting of C-H stretching vibrations have normal mode frequencies of roughly  $3000\text{ cm}^{-1}$ , while the  $\nu_2$  and  $\nu_4$  bands consisting of C-H bending vibrations have normal mode frequencies of roughly  $1500\text{ cm}^{-1}$  [11]. The vibrational bands of methane are grouped into polyads, which are named by the number of interacting bands, including fundamental, overtone, combination, and hot bands, in a given frequency region; the polyads increase in complexity with frequency, making assignment and analysis of the near-infrared and above very difficult.

The pentad region ( $\nu_1, \nu_3, \nu_2 + \nu_4, 2\nu_2, 2\nu_4$ ;  $2300\text{--}3300\text{ cm}^{-1}$ ) has been modeled with high accuracy in the past [2,3,12,13]. Agreement between theory and experiment now surpasses  $0.1\text{ cm}^{-1}$  in the pentad region [2], and will likely soon surpass Doppler-limited precision. In order to continue to provide accurate benchmarks for *ab initio* calculations, line centers must be determined to sub-Doppler uncertainty. Moreover, methane is worth revisiting now due to the advent of more sophisticated techniques and widely tunable high-power mid-infrared light sources during the past few decades, which allow for much higher precision and accuracy in determining line centers.

Sub-Doppler spectroscopy overcomes the limitation of Doppler broadening from traditional spectroscopy. One method of performing sub-Doppler spectroscopy involves the use of a double-pass configuration, where the incident beam serves to saturate the transition, and the reflected beam probes the change in population. When a transition is saturated, a narrow dip in the absorption of the reflected beam is observed. This feature, known as a Lamb dip, is centered at the transition frequency, since it occurs when

\* Corresponding author.

E-mail address: [bjmccall@illinois.edu](mailto:bjmccall@illinois.edu) (B.J. McCall).<sup>1</sup> Current address: Cymer, Inc., 17075 Thornmint Court, San Diego, CA 92127, USA.

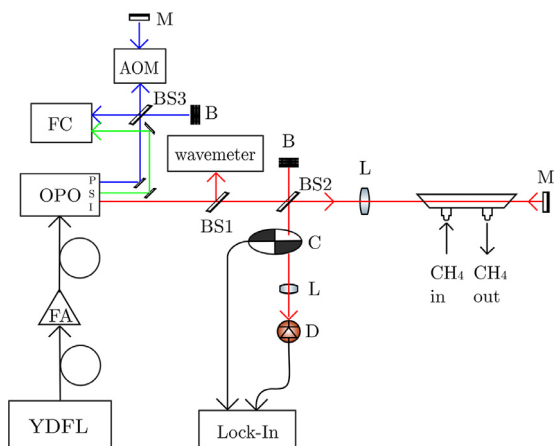

**Fig. 1.** Experimental layout. YDFL: ytterbium-doped fiber laser, FA: fiber amplifier, OPO: optical parametric oscillator, BS1: 99/1 beamsplitter, BS2: 50/50 beamsplitter, B: beam block, L: lens, M: back-reflecting mirror, C: beam chopper, D: detector, BS3: 70/30 beamsplitter, AOM: acousto-optic modulator, and FC: frequency comb.

the counter-propagating beams interact with the same molecules, thereby overcoming Doppler broadening. Lamb dip widths are also roughly two orders of magnitude narrower than a traditional Doppler-broadened profile, since Lamb dips are limited only by the homogeneous line width. When combined with the highly stable frequency calibration provided by an optical frequency comb, sub-Doppler spectroscopy allows for precise and accurate determination of transition frequencies.

The  $\nu_3$  band of methane has been studied quite extensively in Doppler-limited surveys using Fourier transform infrared (FTIR) spectroscopy [13–15] with uncertainties ranging from 3 to 300 MHz and dual-comb spectroscopy [16] where sub-MHz uncertainties were achieved. More recently, several groups have turned to saturation using difference frequency generation sources to perform sub-Doppler spectroscopy with high precision [17,18]. By stabilizing the frequency of the source to saturated absorption lines [19], transitions were recorded with uncertainties of 4–40 kHz. One large-scale sub-Doppler survey performed with cavity enhancement [20,21] covered a total of 204 lines with a typical uncertainty of 3 kHz for allowed transitions and 12 kHz for forbidden transitions, which were observed with wavelength modulation. However, many fairly strong transitions in the pentad region are still known to relatively high uncertainty, which we aim to ameliorate. Here, as an extension of the sub-Doppler work on the  $\nu_3$  band of methane [19–21], we report 22 methane transitions in the pentad region with uncertainties improved by at least an order of magnitude [4,13,14,22].

## 2. Experimental

A diagram of the instrument is shown in Fig. 1. 1064 nm light from an ytterbium-doped fiber laser (Koheras Adjustik Y10) is sent to an erbium-doped fiber amplifier (IPG Photonics YAR-10K-1064-LP-SF), which amplifies the light to 8 W. The amplified light is sent to an optical parametric oscillator (OPO; Aculight Argos 2400 SF) to generate idler (400 mW, 3.2–3.9  $\mu\text{m}$ ) and signal beams via parametric down-conversion. The idler beam is sent through a 40 cm glass flow cell filled with 75–470 mTorr of  $^{12}\text{CH}_4$ , and is reflected back through the cell. The reflected beam is picked off by a 50/50 Si beamsplitter, modulated by a beam chopper, and focused on a fast mid-infrared photodiode detector (Boston Electronics Vigo, PVM-10.6). The detector output is sent to a lock-in amplifier referenced by the frequency of the chopper. The scans shown here were recorded with a 0.1 MHz step size and a 300 ms time constant.

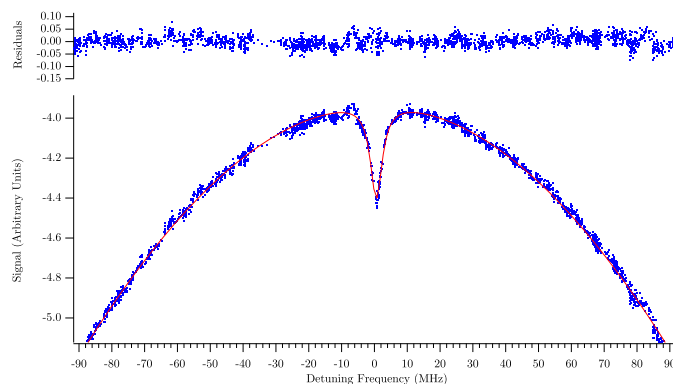

**Fig. 2.** A representative scan of the  $F_2$  component of the  $Q(3)$  transition, centered at 90,488,114 MHz. The dots are the data points, and the curve is the fit. The dots plotted above are the residuals of the fit. The width of the Lamb dip is 4.18 MHz (FWHM).

Frequency calibration of the idler is derived from the difference of the pump and signal frequencies ( $\nu_{idler} = \nu_{pump} - \nu_{signal}$ ), which are calibrated with an optical frequency comb (Menlo Systems FC-1500; 100 MHz repetition rate). An infrared wavemeter (Bristol 621:R-A) is used for crude frequency calibration and to help determine the number of comb modes between the pump and signal frequencies. The signal beam is locked at an offset of 20 MHz to a single comb tooth via a phase-locked loop, with corrections sent to a piezoelectric transducer (PZT) on the signal cavity within the OPO.

The pump beat is kept within the 25–35 MHz internal bandpass of a frequency counter with a feed-forward mechanism using a freespace acousto-optic modulator (AOM; Brimrose IPF-200-80-1600) in a double-pass configuration using a 70/30 beamsplitter. The idler is stepped by incrementing the voltage sent to the seed laser's PZT by an amount which corresponds to a 0.1 MHz shift in frequency. The AOM then applies a correction to the pump to re-center it within the bandpass of the frequency counter, which is calculated by the acquisition software. The frequency counter reads the beat note frequency, and if it is not in the center of the bandpass, additional AOM corrections are made. Once the beat is centered, a data point is acquired, and the voltage is then stepped again to collect another data point. When the AOM reaches the edge of its diffraction efficiency, the frequency is either increased or decreased accordingly by 50 MHz to create a 100 MHz shift to the next comb tooth. Each point was collected after a 1.5 s delay to allow the frequency counters to update.

## 3. Results and discussion

A representative scan is shown in Fig. 2, which is the  $F_2$  component of the  $Q(3)$  transition of the  $\nu_3$  band. Transitions typically had Doppler widths of approximately 400 MHz (full width at half maximum, FWHM) and Lamb dip widths of approximately 4.5 MHz (FWHM). This is attributed to a combination of pressure broadening, power broadening, transit-time broadening, and broadening from the spectral linewidth of the laser. As an example, in the case of the  $F_2$  component of the  $Q(3)$  transition, the self-broadening coefficient for the  $J'' = 3$  state is estimated to be  $0.079 \text{ cm}^{-1}/\text{atm}$  [23] (half width at half maximum, HWHM), or 6.23 MHz/Torr (FWHM). Pressures of 75–470 mTorr translate to widths of 0.4–2.4 MHz. The Einstein A coefficient for this transition is estimated to be 24.7 Hz [4], giving a transition dipole moment of  $\sim 0.054 \text{ D}$ . The incident beam had a power of about 200 mW with a beam waist of about 0.32 mm, translating to power broadening of about 1 MHz. Transit-time broadening was estimated to be 0.9 MHz. Broadening from the spectral linewidth of the radia-

Download English Version:

<https://daneshyari.com/en/article/7845884>

Download Persian Version:

<https://daneshyari.com/article/7845884>

[Daneshyari.com](https://daneshyari.com)