



4th International Conference on Power and Energy Systems Engineering, CPESE 2017, 25-29
September 2017, Berlin, Germany

Designing Optimal Passive Filters for Transformers under Harmonic Conditions

Kasra Abolfathi^a, Mojtaba Babaei^{b,*}, and Amir Ahmarinejad^c

^{abc}Electrical Engineering Department, Yadegar-e-Imam Khomeini (RAH) Shahr-e-Rey Branch, Islamic Azad University, Tehran, Iran

Abstract

Power transformers are designed to supply linear loads at nominal frequency; however, the development of power electronic devices and controllable loads that is generally called non-linear loads is promotion. Non-linear loads lead to temperature rise of transformers significantly and causes decrease their lifespan dramatically. In addition harmonics causes reduced power factor, which causes to reduce active power delivered to consumers. One of the methods to prevent and reduce harmonics is to use C-type passive filters regarding their advantages over other types of filters. Determining the relevant parameters is prerequisite to the application of such filters.

In this paper, model of distribution transformer considering the effects of harmonic and saturation with C-type passive filters is optimized. Performance of different optimizing methods is compared with each other in optimization of model's parameters. Simulation results shown the invasive weed optimization method is an intelligent optimization method with appropriate performance compared with other methods.

© 2017 The Authors. Published by Elsevier Ltd.

Peer-review under responsibility of the scientific committee of the 4th International Conference on Power and Energy Systems Engineering.

Keywords: Harmonic distortion; C-type filter; Optimal design; transformer

1. Introduction

Current harmonics caused by non-linear loads have been increased significantly in the grid. These non-sinusoidal currents cause non-sinusoidal voltage drops on the lines and other loads. Accordingly, several works have been focused on the designed passive filters to maximize the classical power factor expression in the literature [1]-[4].

Abdel Aleem et al provide optimal passive filter design method for to maximize the power factor, where line losses in non-sinusoidal voltage and current conditions is considering frequency-dependent. The numerical results

* Corresponding author. Tel.: +989127002635; fax: +982155229383.

E-mail address: mba_babaei@yahoo.com

show that the proposed method significantly improved losses line, and loading capability of transformer in non-sinusoidal conditions, compared with the conventional method [1]. Also the total harmonic distortion of current and voltage are acceptable in according to IEEE standard 519 [5]. However; the disadvantage of this method is that the optimization problem was solved by a classic optimization algorithm. Which will be shown in a situation that the initial response to this algorithm does not selected nearly the final optimal value that may fail. The performance intelligent optimization methods will be much better than the classic method. In this paper, optimal filter parameters are calculated by using different optimization algorithms to maximize the suggested power factor function.

2. Modelling of the studied system

As previously mentioned, the model used in this paper is the same as model used in [1]. It is Single-phase equivalent circuit of the studied system is given in fig 1(a), and Single-phase circuit of the C-type filter given in fig 2(b). The convergence of different optimization techniques to achieve optimal for final-value system will be evaluated with the same characteristics. Decision variables optimization problem of the optimal filter parameters, the damping resistance R_F , the main capacitor series X_{CF1} and, parallel capacitor X_{CF2} . considered indicators are Loading capability for the power cable DF_{CB} and, Transformers DF_{TR} , total harmonic distortion for voltage THD_V , and for current THD_I , Classic power factor PF , Power factor suggested PF_e , total active power P , Classic apparent power S , apparent power suggested S_e , total transmission and distribution line loss ΔP_{TotalN} , Copper losses ΔP_{CU} , Eddy current losses ΔP_{EC} , total other stray losses ΔP_{OSL} , load Losses ΔP_{EE} , These indicators are considered in conditions harmonic. In addition The transformer saturation effect, is evaluated. To verify performance optimization methods, two cases (Case 1 and Case 2), which consist of Cable 1 and Cable 2 is used. for determine The filter performance to improve power factor and reduce losses, the results have been expressed in both without filter and with filter explained. Two cables introduced in table 1. Specifications power supply, transformer and, load is provided in table2.

Table 1. Properties of the cables simulated with the studied system[1]

Cases Cable properties	$R_{CB}(\Omega/\text{km})$	$X_{CB}(\Omega/\text{km})$
6.35 kV, Trefoil formation, PVC insulated, Unarmoured, Single core copper wire 240 mm ² cross sectional area	0.098	0.1037
6.35 kV, Flat spaced formation, PVC insulated, Unarmoured, Single core aluminium wire, 240 mm ² cross sectional area	0.161	0.1634

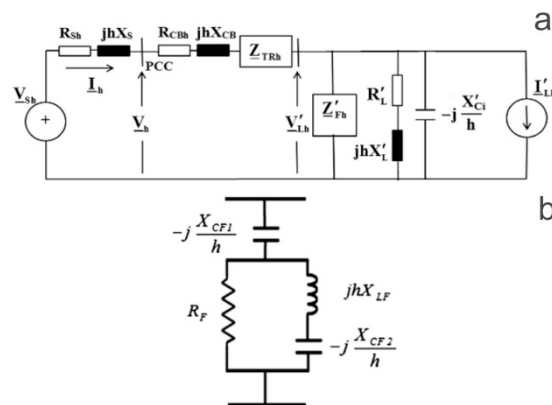

Fig. 1. (a) is Single-phase equivalent circuit of the studied system; (b) and Single-phase circuit of the C-type filter.

Download English Version:

<https://daneshyari.com/en/article/7917414>

Download Persian Version:

<https://daneshyari.com/article/7917414>

[Daneshyari.com](https://daneshyari.com)