

11th CIRP Conference on Intelligent Computation in Manufacturing Engineering - CIRP ICME '17

## Simulation modeling of assembly processes in digital manufacturing

Andrey Kutin<sup>a,\*</sup>, Vitaly Dolgov<sup>a</sup>, Alexey Podkidyshev<sup>a</sup>, Alexander Kabanov<sup>b</sup>

<sup>a</sup> Production Engineering Department of the Moscow State University of Technology STANKIN, Vadkovskij per. 1, Moscow, 127994, Russian Federation

<sup>b</sup> Department of Aerospace Engineering of the Moscow Aviation Institute (National Research University), Volokolamskoe shosse, 4, Moscow, 125993, Russian Federation

\* Corresponding author. Tel.: 7-499-973-30-80; fax: +7-499-973-3080. E-mail address: [aa.kutin@stankin.ru](mailto:aa.kutin@stankin.ru)

### Abstract

Method is proposed for simulation modeling of assembly processes in digital manufacturing, allowing considering influence of intersections of main material flows of different products at same workplaces, component supply interruptions, as well as non-productive time losses due to organizational or technical causes on performance parameters of assembly processes. Simulation modeling has shown 34 % increase of manufacturing system productivity.

© 2017 The Authors. Published by Elsevier B.V. This is an open access article under the CC BY-NC-ND license

(<http://creativecommons.org/licenses/by-nc-nd/4.0/>).

Peer-review under responsibility of the scientific committee of the 11th CIRP Conference on Intelligent Computation in Manufacturing Engineering

**Keywords:** Simulation modeling; Assembly processes; Digital manufacturing.

### 1. Introduction

Efficiency of digital machine-building manufacturing is determined by ability to precisely estimate technological and production cycles of product assembly [1].

There are several ways to define technological and production cycles for finished products:

- using analytical dependencies;
- based on network graphs;
- based on the results of simulation experiments.

In general, accurate estimates of the considered cycles can be obtained using each of the named methods. However, for the same level detailing calculations, the complexity of implementation for each one will very significantly. Mostly it is typical for discrete multiproduct machine-building industries, which produce complex multi-component products (Fig. 1).

It is quite difficult to develop a universal analytical model that would allow us to get accurate time estimates of production of final products for various production situations, subject to the production of the components of final products in batches.

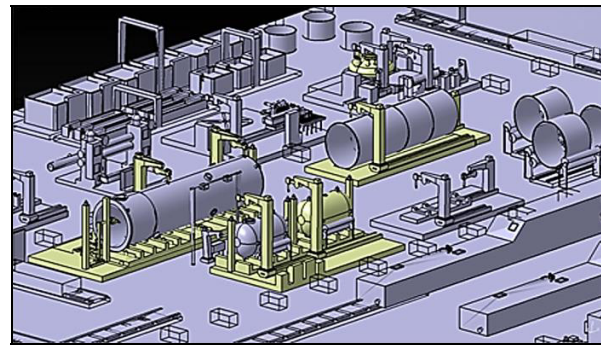

Fig. 1. The model assembly shop for production of multi-component products.

This also applies to methods based on network graphs. At the same time, these models make it possible to quickly obtain a result under relatively simple conditions.

Construction, verification and validation of simulation model of assembly production is also a difficult process. However, this method provides advantages when an analytical solution is difficult to obtain and when the simulated production system is highly variable.

For the production in question, assembly processes are very complex. Therefore, the development of a complete detailed simulation model of the entire assembly production can take a very long time, and in conditions of great uncertainty, for example, during the initial stages of designing or modernizing enterprises, it is not advisable in connection with the lack of data the description of operating conditions.

In conditions of high uncertainty rationally calculate rough values of technological and production cycles, using analytical and graphical models, for example using the critical path method (CPM). For more accurate estimates of cycles, it is recommended to develop the simulation model, when basic decisions for the production system are already determined.

**2. Method of assembly processes modeling**

The essence of the proposed method consists in the sequential application and the further exclusion of a number of assumptions about implementation of assembly processes of manufacturing final products, starting with the upper level assemblies, and then to elementary subassemblies into two categories:

- assumptions related to the simplification of the operating conditions of the production systems;
- assumptions related to the simplification of the composition of elements.

The simplification of first category makes it possible to simplify the process of modeling and reduce volume of rework, using a series of mathematical models. The output results of previous models being input for the following models. The assumptions made at the previous stage of modeling are successively eliminated at each subsequent of modeling. A consistent refinement of the conditions for the implementation of assembly processes and the types of models used in this case is shown in Table 1.

Table 1. Possibilities of model types to account for assumptions in the calculation of production cycles.

The calculation performed under condition	Model based on:			
	Analytical dependencies	Network graphs	Cyclograms	Simulation
Aggregated calculations the total workload of assembly processes	X	X		X
Technological sequence of assembly processes		X		X
Production batches: the lot size is constant		X	X	X
the lot size is variable		X	X	X
A schedule of works			X	X
Shift run			X	X
Failures			X	X
Manufacturing defects				X
Etc.				X

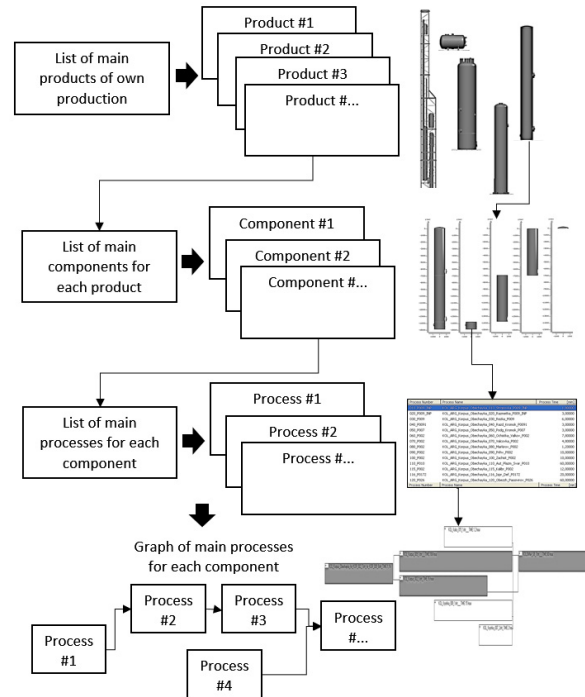

Fig. 2. Flowchart of the sequence of selecting the main objects for the first stages of modeling.

The simplification of two category makes it possible to reduce the dimension of the problem and understand the main regularities in the analyzed production system. For example, on the first stage of analysis only the basic elements of assembly units are considered.

Figure 2 shows a consistent application of simplification of this type in the calculation of production cycles for one of the discrete engineering companies.

First, based on the analysis of the product release program, the main products are identified, which determine the load capacity of the enterprise, the first step of Figure 2.

Next, for each selected product, the main assembly units defining the duration of the manufacturing cycle of the product are determined, the second step of Figure 2.

For each such assembly unit, a sheet of basic manufacturing processes is formed, including both technological and production processes, the third step of Figure 2. Moreover, since assembly processes differ from the fabrication processes in that they are performed in a sequential-parallel scheme, then a network graph of the assembly process is formed from the obtained list of processes. Based on this graph the calculation of the technological or production cycles are performed, the fourth step of Figure 2.

Technological cycle of assembly is determined by critical part of assembly process, which contains technological operations of component assembly, which occur simultaneously or both simultaneously and sequentially, and total duration of which is the longest. For the same product, there is one critical and several near-critical paths.

Duration of assembly technological cycle is determined for one unit of product.

Download English Version:

<https://daneshyari.com/en/article/8050430>

Download Persian Version:

<https://daneshyari.com/article/8050430>

[Daneshyari.com](https://daneshyari.com)