

# Accepted Manuscript

Deep seawater intake for primary cooling in tropical offshore processing of natural gas with high carbon dioxide content: Energy, emissions and economic assessments

Matheus de Andrade Cruz, Ofélia de Queiroz Fernandes Araújo, José Luiz de Medeiros



PII: S1875-5100(18)30264-6

DOI: [10.1016/j.jngse.2018.06.011](https://doi.org/10.1016/j.jngse.2018.06.011)

Reference: JNGSE 2610

To appear in: *Journal of Natural Gas Science and Engineering*

Received Date: 16 February 2018

Revised Date: 28 May 2018

Accepted Date: 5 June 2018

Please cite this article as: de Andrade Cruz, M., de Queiroz Fernandes Araújo, O., de Medeiros, J.L., Deep seawater intake for primary cooling in tropical offshore processing of natural gas with high carbon dioxide content: Energy, emissions and economic assessments, *Journal of Natural Gas Science & Engineering* (2018), doi: 10.1016/j.jngse.2018.06.011.

This is a PDF file of an unedited manuscript that has been accepted for publication. As a service to our customers we are providing this early version of the manuscript. The manuscript will undergo copyediting, typesetting, and review of the resulting proof before it is published in its final form. Please note that during the production process errors may be discovered which could affect the content, and all legal disclaimers that apply to the journal pertain.

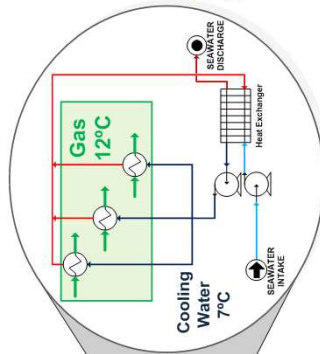

### COMPRESSORS

$$Power = \frac{q \cdot Z \cdot R \cdot T_1 \cdot (P_2)^{\frac{n-1}{n}} \cdot (P_1)^{\frac{1-n}{n}}}{3.600 \cdot \eta_p \cdot MW \cdot \frac{n-1}{n}}$$

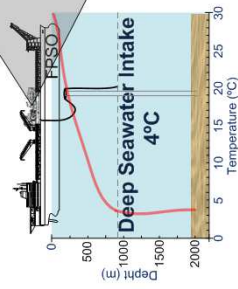

Download English Version:

<https://daneshyari.com/en/article/8127876>

Download Persian Version:

<https://daneshyari.com/article/8127876>

[Daneshyari.com](https://daneshyari.com)