

# Performance analysis of different top metal electrodes in inverted polymer solar cells



M. Suresh Kumar, K. Balachander\*

Nanotechnology Research, Innovation & Incubation Centre, PSG Institute of Advanced Studies, Coimbatore 6410 04, Tamil Nadu, India

## ARTICLE INFO

### Article history:

Received 19 June 2015

Accepted 24 November 2015

### Keywords:

Polymer solar cells  
Open-circuit voltage  
Buffer layers  
Conjugated polymers  
Metal electrodes

## ABSTRACT

In recent years, since the introduction of bulk heterojunction concept in an organic solar cell, the efficiency is increased to ~6%. The benefits of bulk heterojunction (BHJ) organic solar cells are drawing interest for applications in next-generation solar cells. In this study, we analyze the optimal top electrode for practical polymer solar cells (PSC) fabrication by utilizing the optical properties of the electrode material and study their performance of PSC devices. The high work function metal electrodes having enhanced optical properties such as aluminum (Al), silver (Ag) and gold (Au) are considered in fabricating inverted PSC devices. It comprises of a blended polymer of poly(3-hexylthiophene) (P3HT) and phenyl-C<sub>61</sub>-butyric acid methyl ester (PCBM). Among the key photovoltaic parameters, the open circuit voltages ( $V_{oc}$ ) were **strongly affected by the optical properties of the top electrode**. From the experimental evidence, the increase in  $V_{oc}$  of the Al and Ag electrode devices were found to be approximately 11.32% and 26.42% respectively. These values were significantly higher when compared to the Au electrode, as the parasitic absorption of incident photons were below 600 nm. Ag electrodes have excellent stability to ambient exposure which is comparable to Au. These investigations directed to conclude that, Ag is the optimal top electrode material for use in inverted devices. Also, in this study we investigated the incorporation of monodispersed ZnO as an n-type buffer layer to effectively transport electrons from active layer to the cathode electrode.

© 2015 Elsevier GmbH. All rights reserved.

## 1. Introduction

The demand for energy is increasing day by day and various alternate sources of energy are being developed to primarily meet the energy deficit. Polymer solar cells (PSCs) based on semiconducting polymers have attracted much attention due to their potentially low production cost, usage of environmental-friendly production methods, flexible nature and solution based processing techniques which makes it compatible for light weight, large-area and roll-to-roll production techniques [1–4]. Bulk heterojunction (BHJ) solar cells are formed by intermixing of (6,6) phenyl-C<sub>61</sub>-butyric acid methyl ester (PCBM) as the electron acceptor at the nano-scale with an organic semiconducting polymer poly(3-hexylthiophene) (P3HT) as the electron donor having much larger interface area between acceptor and donor dissociates excitons efficiently by generating free electrons and holes. The power conversion efficiency (PCE) of the polymer solar cells

has reached 6% as reported by researchers [5,6] and still needs development in stability and mass production techniques for commercialization [7]. Polymer solar cells with inverted structures (iPSCs) are more stable compared to the conventional type solar cells, as it avoids the usage of corrosive hygroscopic p-type buffer layer such as poly(3,4-ethylenedioxythiophene):poly(styrene sulphonic acid) (PEDOT:PSS) to mainly evade the unfavorable reaction between PEDOT:PSS and transparent conducting electrode. Also, in the conventional PSCs, the usage of low work function metals such as aluminum gets easily exposed to air, promoting oxidation and degradation of the active layer due to oxygen and moisture diffusion through pinholes and grain boundaries of the cathode top metal electrode.

The geometry of the PSCs can be determined by the usage of buffer layer between the active layer and the metal. For inverted polymer solar cells (iPSCs), the polarity of the transparent conducting electrode (Indium doped tin oxide, ITO) can be modified with an appropriate n-type buffer layer to effectively collect the electrons produced in conjugated polymers. Similarly, polarity of top metal electrode can be determined by inserting p-type buffer layer between the top metal electrode and the active layer. The stability of iPSCs can also be improved by the usage of the high-work

\* Corresponding author. Nanotech Research Innovation & Incubation Centre, PSG Institute of Advanced Studies, Coimbatore - 641 004, India. Tel.: +91-99628-41934.  
E-mail address: [kbr@psgias.ac.in](mailto:kbr@psgias.ac.in) (K. Balachander).

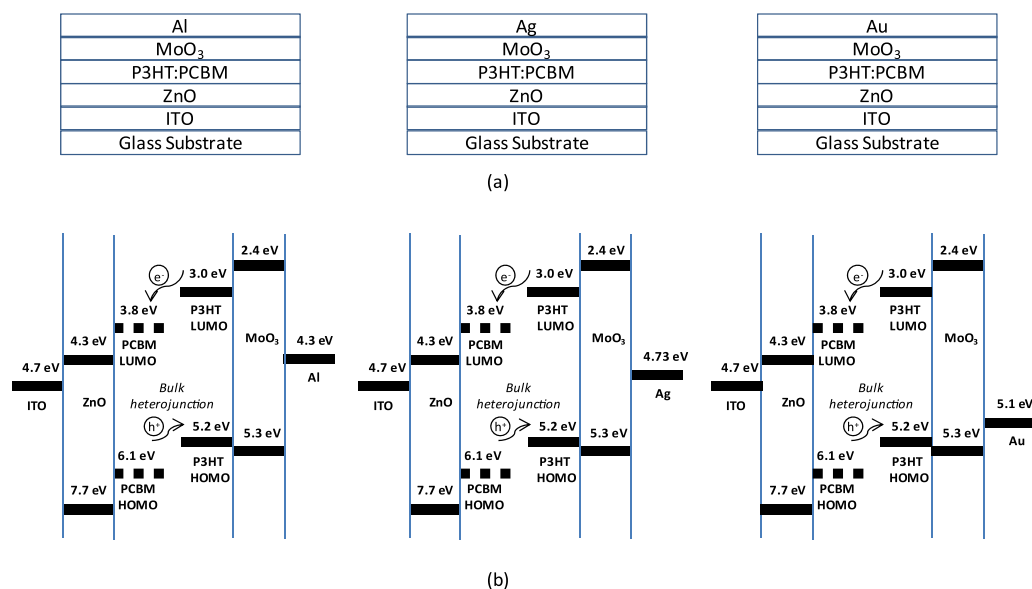

Fig. 1. (a) Schematic structure of inverted OPV cell with different anodes; (b) corresponding energy level diagrams of inverted OPV configuration.

function materials such as Ag and Au as a top metal electrode, which are relatively less air-sensitive and are able to effectively collect holes from an active layer. Materials such as titanium oxide (TiO<sub>x</sub>) [8–10] and zinc oxide (ZnO) [11,12] are some of the effective n-type buffer layer used as electron transport layer. Among these metal oxides, ZnO is the most prominent material as an n-type buffer layer of iPSCs with good electrical and optical properties, thermal and chemical stability, earth abundant, low-cost, non-toxic, low crystallization temperature, large exciton binding energy (60 meV), and facile synthesis [13]. Also, the absorption of the photon depends on the size of the nanoparticles. In this work; we have primarily discussed the size effect of ZnO nanostructures using effective mass model. The p-type metal oxide buffer layer such as vanadium (V) oxide (V<sub>2</sub>O<sub>5</sub>) [14], tungsten trioxide (WO<sub>3</sub>) [15], molybdenum trioxide (MoO<sub>3</sub>) [16] and cuprous oxide (Cu<sub>2</sub>O) [17] are used as a hole transport layer. Among these p-type buffer layers, MoO<sub>3</sub> were chosen as a hole transporting material between active layers and the top metal electrode. The schematic structure of the iPSCs is shown in Fig. 1.

It is critical to choose the n-type buffer layer that doesn't affect the electrical conductivity and the excellent optical properties of the ITO cathode in an iPSCs. The parameters to determine the power conversion efficiency (PCE) of the thin film PSCs are the short-circuit current ( $J_{SC}$ ), the open-circuit voltage ( $V_{OC}$ ), and the fill factor (FF). The  $J_{SC}$  is sensitive to the film morphology, solvent type, or deposition methods [18,19]. The performances of BHJ solar cells based on polymer/fullerene blend are also significantly dependent on the type of the top metal electrode. Therefore it is critical to study the role of top metal electrodes to enhance the overall performance of the device. In this work, the iPSCs device performance were studied using various top metal electrodes and were focused to identify the optimal top metal electrode to use as an anode material in iPSCs.

## 2. Experimental procedure

### 2.1. Materials used

Zinc acetate dihydrate (Zn(Ac)<sub>2</sub>·2H<sub>2</sub>O) and Ethylene glycol (AG) were purchased from Merck chemicals. Sodium hydroxides (NaOH pellets) were purchased from Himedia. Oleic acids used in the synthesis of monodispersed ZnO were purchased from Fisher Scientific.

Chloroform (LR) was purchased from Ranbaxy. The active materials such as poly(3-hexylthiophene-2,5-diyl) (P3HT) (≥90% pure) and [6,6] - Phenyl C<sub>61</sub> butyric acid methyl ester (PCBM) (≥99.5% pure) were purchased from Sigma Aldrich. Molybdenum tri-oxide (MoO<sub>3</sub>) and aluminum wires (99.999% pure) were purchased from Sigma-Aldrich.

### 2.2. ZnO preparation

All the chemical reagents used in the synthesis are of analytical grade and used without further purification. ZnO nanoparticles were prepared by an improved method, which is reported elsewhere in the literature [20–22] and more detailed in the procedure [23]. The typical procedure to synthesize monodispersed ZnO (MD-ZnO) nanoparticles involves Zn(Ac)<sub>2</sub>·2H<sub>2</sub>O, NaOH and Oleic acid as a starting precursors. A solution of zinc acetate was prepared by dissolving 0.04 M Zn(Ac)<sub>2</sub>·2H<sub>2</sub>O in 100 ml of ethylene glycol and stirred with a magnetic stirrer at the temperature of 80 °C for 1 h. The NaOH solution was prepared by dissolving 0.04 M NaOH in 100 ml of ethylene glycol and stirred using magnetic stirrer under room temperature for about 20 min. The NaOH solution was slowly added drop by drop to zinc acetate solution under rigorous magnetic stirring for 3 h at room temperature. The mixture was then ultrasonically treated for 30 min before the addition of oleic acid to the solution mixture. 0.5 ml oleic acids were used as a surfactant, which is mainly added to the solution to avoid agglomeration of ZnO nanoparticles. The final product appears as a white precipitate. The white precipitates were washed by centrifuging and throwing away the supernatant several times with double distilled water followed by ethanol, acetone and de-ionized water (DI-H<sub>2</sub>O). The resulting product was dried in vacuum at room temperature. The obtained monodispersed ZnO nanoparticles were used as an electron transport layer in the inverted organic solar cell structure.

### 2.3. Device fabrication

The inverted hybrid solar cell devices were fabricated by spin-coating process. The solar cell structures and energy-level diagram with different electrodes used in this study were illustrated in Fig. 1(a) and (b), respectively. In this structure, ITO acts as a cathode material, ZnO acts as an electron transport layer, while P3HT:PCBM

Download English Version:

<https://daneshyari.com/en/article/847407>

Download Persian Version:

<https://daneshyari.com/article/847407>

[Daneshyari.com](https://daneshyari.com)